

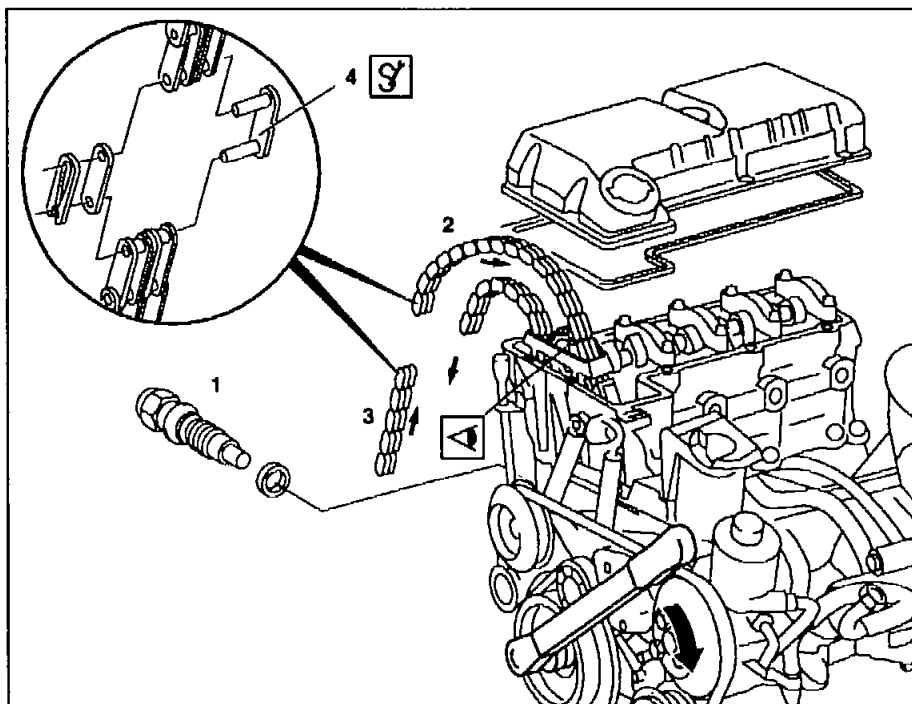











ENGINE 601, 602, 603 (except, 602.982)

- 1 Chain tensioner
 2 Old timing chain
 3 New timing chain
 4 Assembly link 

Ⓛ Only for drawing in timing chain, not suitable for running engine



D05.10-0015-06

	Removing, installing		
1	Remove chain tensioner (1)		05-310
2.1	Remove viscous fan clutch	Engine 601, 602 in model 124, 201 Engine 603 124, 126, 140 Engine 601 in model 202	AR20.40-P-5660HW AR20.40-P-5660HA
3	Remove cylinder head cover		
4	Separate timing chain, rivet	<p>Ⓛ It is essential to remove assembly link (4). It is only an assembly aid and is not suitable for running engine.</p> <p>        </p> <p>Inspect camshaft sprocket for scores and pitting, if necessary ↓ Replace camshaft sprocket</p>	AR05.10-D-7601-03A AR05.10-P-7601HX/2 602 589 00 98 00 602 589 02 33 00 602 589 04 63 00 602 589 04 63 01 602 589 00 39 00 602 589 02 63 00 602 589 03 63 00 602 589 01 40 00 602 589 02 40 00
			
5	Install in the reverse order		

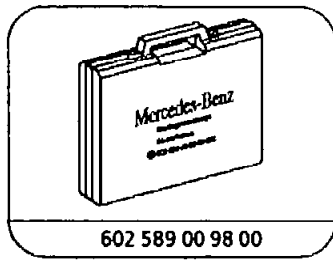

602 589 00 98 00

Case

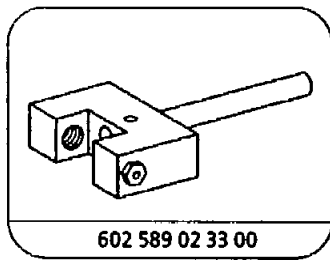

602 589 02 33 00

Chain separating tool

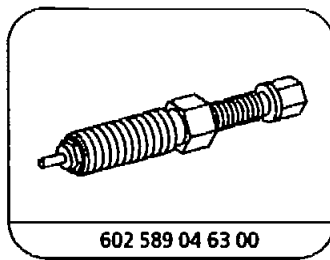

602 589 04 63 00

Thrust spindle

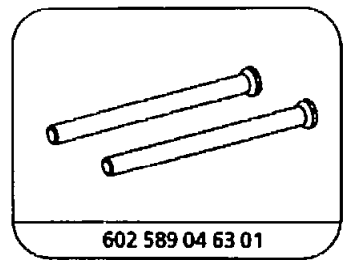

602 589 04 63 01

Thrust pins

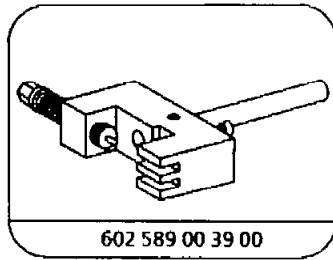

602 589 00 39 00

Riveting tool

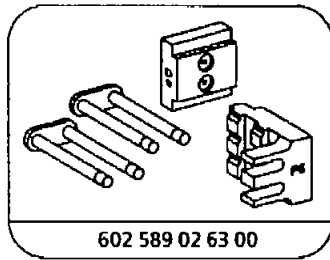

602 589 02 63 00

Assembly inserts

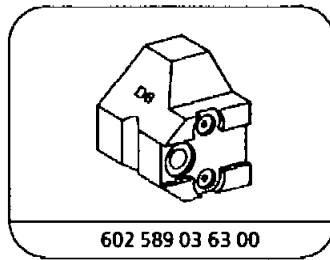

602 589 03 63 00

Thrust piece

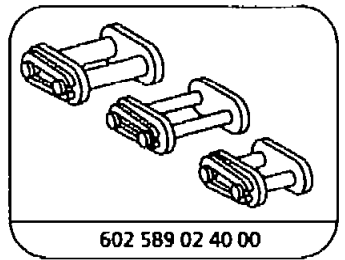

602 589 02 40 00

Assembly links

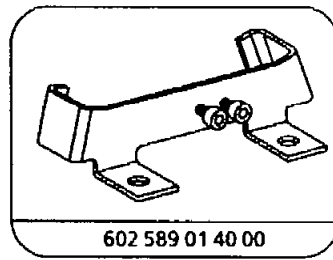

602 589 01 40 00

Retaining device

AR05.10-D-7601-03A	Separating and riveting timing chain	<input checked="" type="checkbox"/> 602 589 04 63 00 Pressing screw <input checked="" type="checkbox"/> 602 589 04 63 01 Thrust pins <input checked="" type="checkbox"/> 602 589 00 98 00 Case <input checked="" type="checkbox"/> 602 589 02 33 00 Chain separating tool <input checked="" type="checkbox"/> 602 589 03 63 00 Thrust piece <input checked="" type="checkbox"/> 602 589 00 39 00 Rivet opener <input checked="" type="checkbox"/> 602 589 02 63 00 Assembly inserts <input checked="" type="checkbox"/> 602 589 02 40 00 Assembly links <input checked="" type="checkbox"/> 602 589 01 40 00 Retaining device	
--------------------	--------------------------------------	---	--

Separating

- 1 Attach retaining device 602 589 01 40 00 to cylinder head with bolts (supplied).
- 2 Place a clean cloth over the chain housing.

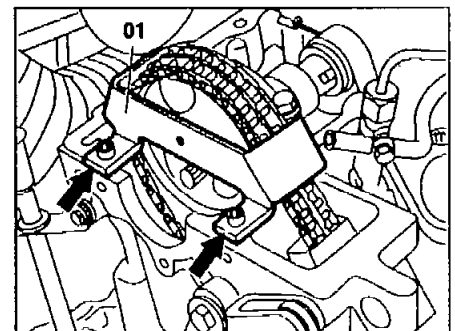

P05.10-0262-01



- 3 Screw thrust spindle (02) 602 589 04 63 00 together with thrust pin 602 589 04 63 01 into the chain separation tool (03) 602 589 02 33 00.
- 4 Position chain separation tool (03) on timing chain.
- 5 Screw in thrust spindle (02) sufficiently until the thrust pin is touching the left timing chain pin (looking in direction of rotation of engine) of a chain link.
- 6 Press out thrust pin of timing chain by screwing in thrust spindle (02a).
- 7 Unscrew thrust spindle (02) and take off chain separation tool (03).
- 8 Remove the chain pin (1) which has been pressed out, from the chain separation tool (03).

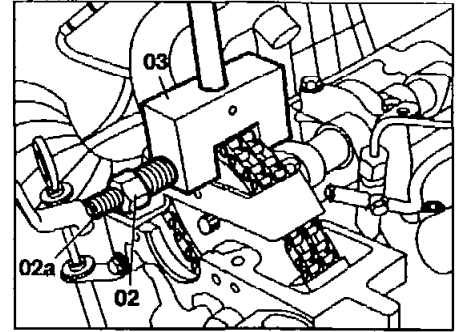

P05.10-0263-01

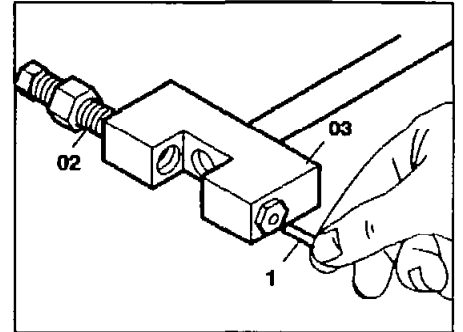

P05.10-0271-01

Inserting

- 9 Connect new timing chain (5) to old timing chain (4) with the connection link (04) 602 589 02 40 00 and secure.
- 10 Rotate engine at crankshaft in direction of rotation of engine and draw in new timing chain (5).
- 11 Remove connecting link (04) and take off old timing chain (4).

ⓘ It is essential to remove connecting link (04). It is only an assembly aid and is not suitable for engine running.

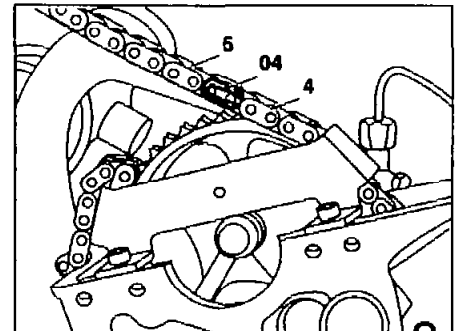

P05.10-0268-01

Riveting

- 12 Insert center plate (2) into the timing chain and fix in place with the assembly link (05).

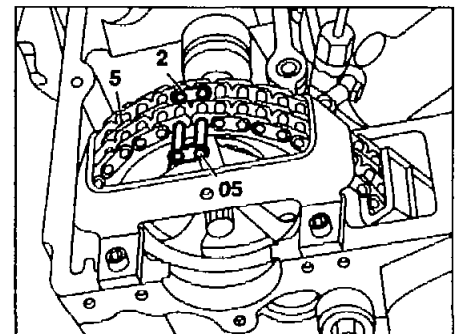

P05.10-0266-01

- 13 Insert assembly inserts (F5 and D9) into riveting tool (06) and screw on.

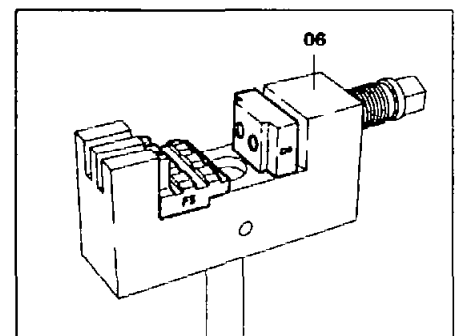

D05.10-0051-01



14 Push riveted link (3) into new timing chain.

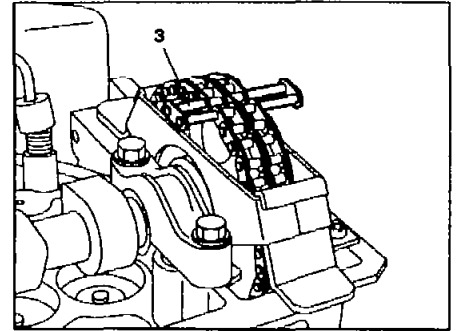

D05.10-0052-01

15 Fit riveting tool onto timing chain.

16 Rotate spindle and press in riveted link (3) as far as the stop.

17 Take off riveting tool.

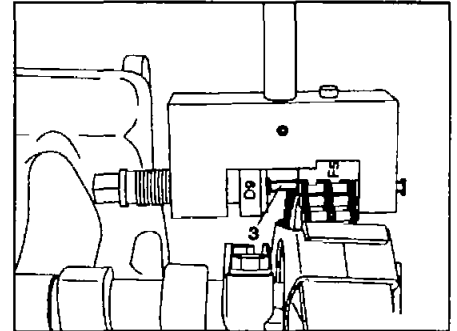

D05.10-0053-01

18 Place riveting Insert (D8) and (F1) into riveting tool (06).

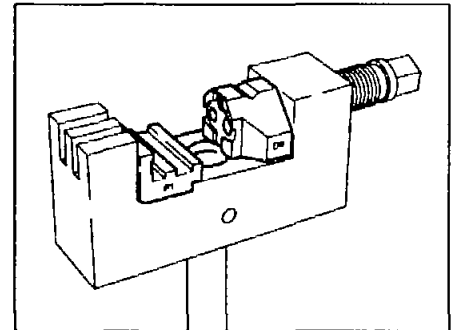

D05.10-0055-01

19 Insert outer plate of riveted link into riveting tool (held by magnet).

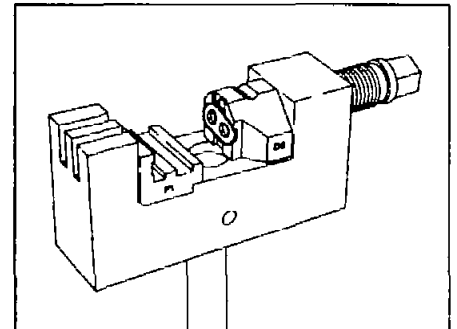

D05.10-0054-01

20 Press on outer plate.

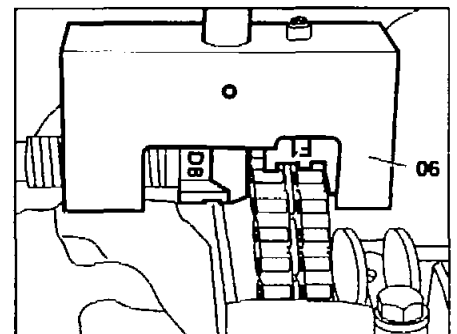

P05.10-0265-01



- 21 Turn over riveting insert (D8).
- 22 Rivet pins of riveted link individually.

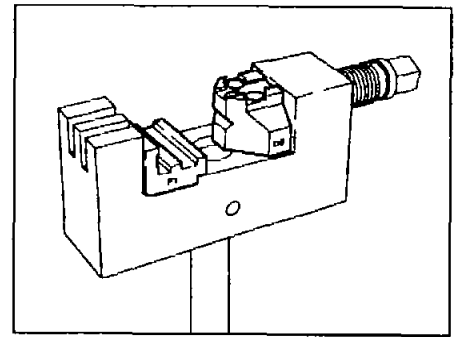

D05.10-0056-01

- 23 Inspect riveting (arrows), re-rivet if necessary.

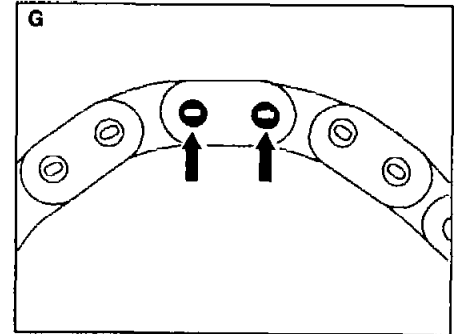

P05.10-0213-01