

A blurred red sports car is shown in motion, moving from left to right across the frame. The background is a soft, hazy sunset or sunrise sky with horizontal bands of color. The car's headlights and front grille are visible, though blurred due to motion. The overall image conveys a sense of speed and performance.

**Garrett®**

*PERFORMANCE PRODUCTS CATALOG*

# CONTENTS

### General Information

Welcome .....	1
History .....	2
What's New .....	3

### Applications & Distributors

GT Performance Distributors.....	4
Engineering Houses .....	5
US & Canadian Master Distributors.....	6-7
Latin America & European Master Distributors .....	8-11

### Turbochargers

Power/Displacement Charts .....	12-13
GT12 - GT60 Turbocharger Range.....	14-28
Additional Models.....	29

### Ancillary Products

Wastegate.....	30
Blow-off Valve .....	31
Intercoolers.....	32-33

### Technical Information

Tech Info .....	34-35
Testing.....	26-27

### Warranty

Statement of Warranty.....	38
----------------------------	----

### Appendix

.....	a.l
-------	-----



**Garrett®**

*PERFORMANCE PRODUCTS*

**Garrett**

**GENERAL INFORMATION**



### THE GARRETT PERFORMANCE PRODUCTS CATALOG

*Welcome to the new Performance Products Catalog! You are about to encounter some of the most innovative turbochargers in the industry today. Whether it is the advanced aerodynamic wheel design or our enhancement of the GT product line, you will see many exciting turbocharging additions within this catalog. One of the most evident modifications to our catalog has been the name itself. The "Ballistic Concepts" title has been changed to reflect our renewed emphasis on performance, and so all future product introductions will be under the "Garrett Performance Products" title.*

Here are some more reasons to investigate the Garrett Performance Products Catalog:

- ▶ The catalog design approach - our team has uniquely modeled this catalog to provide all turbocharger information on one page in an "easy to interpret" manner.
- ▶ Application flexibility - kits are now being offered to allow you to choose the optimal turbocharger for your individual application and provide you the flexibility to upgrade now or in the future. Mixing and matching has never been easier!
- ▶ **Turbine maps!** The Garrett team is thrilled to be the first to provide ALL of the data necessary to ensure the best performance for your vehicle!
- ▶ Garrett is where you want to be! We have engineering teams on 5 continents that are continually innovating to bring the most up-to-date technology to the industry. And, with some of the most rigorous functional testing in the field you know you are buying the superior product.

The Garrett Aftermarket team has a lot in store for the future, so this catalog design will allow for the addition of product pages and other information as we grow our performance product line - so stay tuned for further updates!

-The Garrett Performance Team

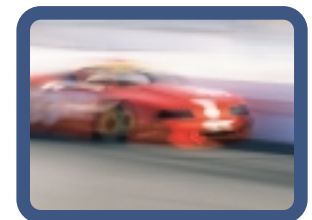

▶ *We are also interested in hearing about your turbocharging opportunities, so please feel free to drop us a line at [garrett.performance@honeywell.com](mailto:garrett.performance@honeywell.com).*

Garrett is the leading innovator of turbochargers in the world, providing engine boosting systems that save fuel and reduce emissions while providing an increase to engine performance.

Garrett's turbocharging business traces its roots to an aerospace company established in California by entrepreneur Cliff Garrett. Over time, the turbocharging business spun off to establish itself as a serious player in the engine boosting industry. Through names such as AiResearch, AlliedSignal, and the Honeywell of today, Garrett has sustained its reputation for innovating turbocharger technologies generation after generation. From its long list of industry firsts to its leading-edge ball bearing turbos for racecars, Garrett develops and manufactures the same cutting-edge boosting expertise that goes into all Garrett products. Most of the world's top engine and car manufacturers employ Garrett turbochargers to boost their engines, and with 28,000 turbos produced EVERY DAY you know the Garrett name is one you can trust. Finally, through the Garrett network of Master and Performance Distributors listed on the next page, Garrett's turbocharging product line is readily available in the aftermarket for you to install on your vehicle!

### MEET GARRETT'S NEWEST TECHNOLOGIES



Garrett's newest turbocharger line delivers these benefits and more over our competitors:

Looking for an efficient, reliable turbocharger that can handle higher boost pressure? Your search ends with the new Garrett Performance Products Catalog. As the industry leader in turbocharging innovation, Garrett turbochargers incorporate the latest advances in boosting technology and aerodynamic design. Whether you're looking to install a new turbocharger or need to upgrade an existing one, you've come to the right place.

#### ► Improved Efficiency

New, efficient turbine stages deliver more power to your engine and allow Garrett turbochargers to spool up faster than ever. Garrett engineers have eliminated old efficiency killers, including on-center turbine housings\*, clipped turbine wheels, and antiquated aerodynamics with the new GT product line.

#### ► Increased Boost Capacity

Garrett's new turbochargers feature compressor wheels that can handle a higher boost pressure. So go ahead—increase the PSI. Your Garrett turbocharger can take it!

#### ► True Ball-Bearing Turbochargers

Thanks to our single-cartridge, dual ball-bearing technology, Garrett turbochargers generate far less frictional drag and are 10 times more durable than traditional journal-bearing turbochargers. While first developed for racing, over 100,000 ball-bearing turbos have been produced for OE applications, and are now available in a range of sizes for the street.

#### ► Proven Durability

The Garrett engineering team puts our turbochargers through more than 20 durability and performance tests before they reach consumers. And since Garrett is the global leader in manufacturing turbochargers, producing more than 7.8 million units every year, you can be assured a Garrett turbo is a dependable one.

\* See Turbo Terms in Appendix

**Garrett®**

*PERFORMANCE PRODUCTS*

**Garrett**

**APPLICATIONS & DISTRIBUTORS**

## **G** PERFORMANCE DISTRIBUTORS

Garrett GT Performance Distributors supply upgrade and hybrid turbochargers, Garrett component parts for a wide variety of turbocharger models, and the expertise to apply and support the Garrett line of GT Ball Bearing Performance Turbochargers.

### **Limit Engineering**

885 Kiowa Ave.  
Lake Havasu City, AZ 86406  
928-453-7321  
928-453-0789 (fax)  
craig@redrivernet.com  
www.limitengineering.com

### **Precision Turbo & Engine**

616A South Main Street  
PO Box 425  
Hebron, IN 46341-8904  
219-996-7832  
219-996-7749 (fax)  
rod@precisionturbo.net  
www.precisionturbo.net

### **Turbos Direct**

2408 Grand Ave.  
Phoenix, AZ 85009  
602-989-0611  
602-253-2641 (fax)  
turbosdirect@qwest.net

### **TiAl Sport**

616 Cass Street  
Owosso, MI 48867  
989-729-8553  
989-729-9973 (fax)  
www.tialsport.com

### **Advanced Tuning Products**

44777 South Grimmer Blvd.  
Fremont, CA 94538  
510-445-1682  
510-445-1692 (fax)  
info@atpturbo.com  
www.atpturbo.com



### ENGINEERING HOUSES

Garrett Engineering House accounts provide the performance market with retro fit turbocharger kits, complete systems and upgrade turbochargers.

---

#### Ford, GM & Dodge Trucks

Gale Banks Engineering  
546 Duggan Avenue  
Azusa, CA 91702  
626-969-9600  
626-969-9600 (fax)  
peter@galebanks.com  
www.bankspower.com

---

#### Nissan / Infinity

Jim Wolf Technology  
212 Millar Avenue  
El Cajon, CA 92020  
619-442-0680  
619-579-8160 (fax)  
jim@jimwolfttechnology.com  
www.jimwolfttechnology.com

---

#### GM

Lingenfelter Performance Engineering  
1557 Winchester Road  
Decatur, IN 46733  
260-724-2552 X303  
260-724-0422 (fax)  
jhaines@lingenfelter.com  
www.lingenfelter.com

---

#### Audi & Volkswagon

Audi Performance Racing  
1027-B Opelika Road  
Auburn, AL 36830  
800-680-7921  
334-502-5180 (fax)  
flora@goapr.com  
www.goapr.com

---

#### Toyota, Chevrolet, GMC

Squires Turbo Systems  
535 North 1200 West  
Orem, UT 84057  
801-979-6554  
ststurbos@hotmail.com  
www.ststurbo.com

---

#### Turbo Specialties

17906 Crusader Ave  
Cerritos, CA 90703  
562-403-7039  
562-403-7040 (fax)  
res05505@gte.net

---

#### Honda

Edelbrock  
2700 California Street  
Torrance, CA 90503  
310-781-2222  
310-320-1187 (fax)  
jdralle@edelbrock.com  
www.edelbrock.com

---

#### Honda (Motorcycle)

Velocity Racing  
2240 S.W. 70th Ave #C-1  
Davie, FL 33317  
1-866-4-1-SPEED  
www.velocityracing.com

### MASTER DISTRIBUTORS

Garrett Master Distributors supply the market with the complete offering of the Garrett Aftermarket product line.

---

#### D&W Diesel – Eastern PA, NJ, NY, CT, RI, MA, NH, VT, ME, and Canada

**D&W Diesel, Inc.**  
1503 Clark Street Road  
Auburn, NY 13021  
315-253-7740  
315-282-0031 (fax)  
r.banas@dwdiesel.com

**D&W Diesel, Inc.**  
20 Saginaw Drive  
Rodchester, NY 14623  
315-253-7740  
315-282-0031 (fax)  
r.banas@dwdiesel.com

**D&W Diesel, Inc.**  
731 Main Street  
North Oxford, NY 1537  
315-253-7740  
315-282-0031 (fax)  
r.banas@dwdiesel.com

**D&W Diesel, Inc.**  
14201 Industrial Ave., South  
Cleveland, OH 44137  
315-253-7740  
315-282-0031 (fax)  
r.banas@dwdiesel.com

**D&W Diesel, Inc.**  
3005 Walden Ave.  
Depew, NY 14043  
315-253-7740  
315-282-0031 (fax)  
r.banas@dwdiesel.com

**D&W Diesel, Inc.**  
13 Warehouse Row  
Albany, NY 12205  
315-253-7740  
315-282-0031 (fax)  
r.banas@dwdiesel.com

---

#### Diesel Injection & Electric – FL, AL, GA, SC, NC, VA, DE, MD, DC, and Canada

**Diesel Injection & Electric Co.**  
231 Main Street  
Forest Park, GA 30297  
800-241-4389  
404-361-1701 (fax)  
turboparts@dinjection.com

**Turbo Fuel & Electric**  
2437 Silver Star Road  
Orlando, FL 32804  
407-294-8222  
407-298-0301 (fax)  
tfe@dinjection.com

**Promotive Power**  
1647 Canton Road  
Marietta, GA 30066  
770-424-0330  
770-427-9917 (fax)  
pro@dinjection.com

**Fuel & Electric Systems**  
3806 2nd Avenue South  
Birmingham, AL 35222  
800-633-4392  
205-592-3344 (fax)  
fuel.electric@dinjection.com

**Lews Diesel & Turbo**  
1051 Guy Paine Road  
Macon, GA 31206  
478-781-8383  
478-781-9319 (fax)  
lewsdiesel@dinjection.com

---

#### Diesel Injection Service – MI, IN, OH, KY, TN, MS, AR, WV, Western PA, CA, OR, WA, ID, NV, AK, HI, Western MT, and Canada

**Diesel Injection Service Co., Inc**  
Distribution Center  
4724 Allmond Avenue  
Louisville, KY 40209  
502-357-7800  
502-364-2929 (fax)  
tombrown@dieselusa.com

**Columbus Diesel Supply**  
1575 Integrity Drive East  
Columbus, OH 43209  
614-445-8391  
614-445-8104 (fax)  
benmosko@dieselusa.com

**Fort Wayne Diesel Service**  
2732 Broadway  
Fort Wayne, IN 46807  
260-456-1277  
260-745-1554 (fax)  
patkiel@dieselusa.com

**Diesel Injection Service Co., Inc**  
Louisville Service Facility  
4710 Allmond Avenue  
Louisville, KY 40209  
502-361-2531  
502-368-7858 (fax)  
rogerlighter@dieselusa.com

**Diesel Injection Service**  
3032 Reading Road  
Cincinnati, OH 45206  
513-281-5315  
513-281-1311 (fax)  
smattstansbury@dieselusa.com

**Turbo & Diesel Injection**  
3760 West Morris Street  
Indianapolis, IN 46241  
317-247-7373  
317-247-5652 (fax)  
vernbeeche@dieselusa.com

### **MASTER DISTRIBUTORS**

Garrett Master Distributors supply the market with the complete offering of the Garrett Aftermarket product line.

---

#### **Area Diesel Service – Eastern KS, ND, SD, MN, IA, WI, IL, MO, MI (Upper Peninsula), and Canada**

Area Diesel Service, Inc.  
North on University - PO Box 115  
Carlinville, IL 62626  
800-637-2658  
217-854-8972 (fax)  
larry@areadiesel.com

Area Diesel Service, Inc.  
1440 North East 56th St.  
Pleasant Hill, IA 50317  
515-265-6303  
515-265-8657 (fax)  
desmoines@areadiesel.com

---

#### **Magneto and Diesel – TX, OK, LA, and Canada**

Magneto and Diesel Service  
6931 Navigation Blvd.  
Houston, TX 77011  
800-392-5517  
713-928-8154 (fax)  
jsandell@mddistributors.com  
www.mddistributors.com

Magneto and Diesel Service  
4828 Calvert St.  
Dallas, TX 75247  
800-395-4003  
214-631-4112 (fax)  
dwilk@mddistributors.com

Magneto and Diesel Service  
1002 Paulsun Dr.  
San Antonio, TX 78220  
800-292-1082  
210-271-0812 (fax)  
jfrizzell@mddistributors.com

Magneto and Diesel Service  
213 Flecha Lane  
Laredo, TX 78044  
800-321-7608  
956-727-5283 (fax)  
nkissman@mddistributors.com

Magneto and Diesel Service  
6904 North Shepherd  
Houston, TX 77091  
713-699-4100  
713-699-1938 (fax)  
krenfro@mddistributors.com

Magneto and Diesel Service  
827 N. Bell  
San Angelo, TX 76903  
800-749-2593  
915-657-0462 (fax)  
mmorris@mddistributors.com

---

#### **Central Motive Power – Eastern MT, WY, UT, AZ, NM, CO, NE, Western KS, and Canada**

Central Motive Power Inc.  
6301 North Broadway  
Denver, CO 80216  
800-822-4332  
303-428-6785 (fax)  
www.centralmotivepower.com

Central Motive Power Inc.  
3740 Princeton DR. NE  
Albuquerque, NM 87401  
800-884-2525  
505-224-1358 (fax)  
mraimondi@centralmotivepower.com

Pueblo Diesel Injection  
36 North Laser Drive  
Pueblo West, CO 81007  
719-647-2092  
719-547-0344 (fax)  
jkramer@centralmotivepower.com

### **MASTER DISTRIBUTORS**

Garrett Latin American Master Distributors supply Mexico, Central America, and the Caribbean with the complete offering of the Garrett aftermarket product.

#### **TURBO SYSTEM DEL NORTE, S.A. DE C.V.**

Ave. Ruiz Cortines # 304  
Fracc Hercules  
Guadalupe N.L., Mexico  
CP 67130  
Tel : 011 52 (818) 394-3230  
Fax : 011 52 (818) 379-0407  
email: turbosystem@prodigy.net.mx  
url: www.turbosystem.com.mx  
Contacts: Jose Luis/Marco Tamez

#### **MARIO DIESEL DE CHIHUAHUA, S.A. DE C.V.**

Ave. Ocampo # 2607  
Col. Centro  
Chihuahua, Chih., Mexico  
CP 31000  
Tel.: 011 52 (614) 415-7715  
Fax : 011 52 (614) 416-0489  
email: mdiesel@prodigy.net.mx  
url: n/a  
Contacts: Mario Acosta

#### **TURBO REFACCIONES DIESEL DE MEXICO, S.A. DE C.V.**

Av. San Antonio # 47  
Col. Mixcoac  
Mexico, D.F. Mexico  
CP 03800  
Tel.: 011 52 (555) 615-0900  
Fax : 011 52 (555) 615-0826  
email: turborefacciones\_diesel@hotmail.com  
url: n/a  
Contacts: Daniel Araizaga

#### **Radiadores Unidos SA de CV**

Av. Pacifico 181 Col. Los Reyes Coyoacán  
México, DF., Mexico  
CP 04330  
Tel 011 52 (555) 617-1068  
Fax 011 52 (555) 619- 5113  
Fax 24 Hrs. 011 52 (555) 544- 6151  
email: runsa@runsa-caosa.com.mx  
url: www.runsa-caosa.com.mx  
Contacts: Arturo Garcia / Martin Rodriguez

#### **TURBOCARGADORES DE GUADALAJARA S.A. DE C.V.**

Salvador Lopez Chavez # 1481  
Col.Quinta Velarde  
Guadalajara, Jal. Mexico  
CP 44430  
Tel. 011 52 (333) 619-0918  
Fax. 011 52 (333) 619-0921  
email: armando@turbocargadores.com  
url: www.turbocargadores.com  
Contacts: Armando/Magda Rojas

#### **Delphi Products & Service Solutions Mexico**

Periférico sur 6369, Col Tepepan,  
Mexico, DF, Mexico  
CP 14610  
Tel. 011 52 (555) 676-9855  
Fax. 011 52 (555) 641-2580  
email: edgar.cruz@delphi.com  
url: www.delphi.com  
Contacts: Edgar Cruz / Marisol Lemus

#### **Central Turbo Corp.**

10809 NW 29th Street  
Miami, FL, 33172  
Tel (305) 406-3933  
Fax (305) 591-9372  
email: sales@centralturbos.com  
url: www.centralturbos.com  
Contacts: Cadu Tilikian

### MASTER DISTRIBUTORS

Garrett European Distributors supply the European region with the complete offering of the Garrett Aftermarket productline.

#### ASSURED PERFORMANCE INTERNATIONAL LTD

Unit 13 Ballymount Court Business Centre  
Ballymount Road  
Walkinstown  
Ireland  
Dublin 12  
00 353 1 4601 482  
00 353 1 4601 489 (fax)  
assuredperformance@indigo.ie

#### B. BARANKIEWICZ & M. LONDNER LTD

34 - 36 ITZHAK SADEH ST  
67212  
TEL AVIV  
Israel  
00 972 356 20359  
00 972 356 17116 (fax)  
lebarlo@netvision.net.il

#### BANE ROCO

SURR-SOJAMAE 19A  
11415  
TALLINN  
Estonia  
372 6 007 764  
372 6 007 765 (fax)  
info@turbo.ee

#### BRAND ENGINEERING

P.O. Box 56511  
CY 3307 Limassol  
Cyprus  
357 558 1007  
357 558 1457 / 0878 (fax)  
Garrett.invoice@brand.cy.net

#### BTN TURBO LTD

Arundel Road Uxbridge Trading Estate  
Uxbridge  
Middlesex  
United Kingdom  
UB8 2SB  
44 01895 466666  
44 01895 466667 (fax)  
kellya@btnturbo.com

#### BUCKER & ESSING GmbH

Bucker unternehmensgruppe GmbH & Co KG  
Turbolader Service Sud GmbH  
Paradeisstra Be 56  
D-82362 Weilheim  
Germany  
49 881 638595  
49 881 627296 (fax)  
matthias.sieker@buecker-gruppe.de  
oliver\_meyer@t-online.de  
markus.schulz@buecker-gruppe.de

#### ENGINE PARTS PTY

Patrick Street, Jet Park  
Bocksburg 1459, P.O. Box 674  
Isando 1600,  
Johannesburg  
South Africa  
27 11 3975280  
27 11 3974403 (fax)  
donh@engineparts.co.za

#### EUGEN TROST GmbH

KesselStra Be 23  
70327 Stuttgart  
Germany  
49 711 4013 421  
49 711 5763 300 (fax)  
heinz.schoellmann@trost.d  
lars.seigemund@trost.d

#### EXPRESS DIZEL POMP SRL

SOS ALEXANDRIEI NR 199E, SECTOR 5  
11111  
BUCHUREST  
Romania  
00 40 21 420 04 33  
00 40 21 420 02 69 (fax)  
ROMDIESEL@DNT.RO

#### GIK TURBOTEKNIK AB

Tagenvagen 30  
S-425 37 Hisings Karra  
Sweden  
46 31 571220  
46 31 572027 (fax)  
info@gikturbo.se

#### H.DAUGBJERG A/S

Industrivej 20  
DK - 2605 Broendby  
Denmark  
45 43961545  
45 43431945 (fax)  
dau@scanturbo.dk

#### HONEYWELL ZAO

LUZHNIKI 24  
119048  
MOSCOW  
7 095 796 98 36  
7 095 796 98 92 (fax)  
konstantin.tsarev@honeywell.com

#### IBEROTURBO

Rua Sebastiao e Silva Cote E12  
Urbanizacao Casal du Olival  
Massama- 2745 Queluz  
Portugal  
063 114 393 385  
35 114 375 468 (fax)  
paulo.marques@bomboleo.com

#### KADEK

Kalite Kara Ve Deniz  
Yedekleri Ticaret Ve Sanayi  
1580/2 Sokak NO. 4/A  
35109 MERSINLI / IZMIR  
Turkey  
90 232 4869067  
90 232 4353559 (fax)

### MASTER DISTRIBUTORS

Garrett European Distributors supply the European region with the complete offering of the Garrett Aftermarket productline.

#### KIRSCHNER TURBO SERVIS

GOLESKA 14/1  
1020  
ZAGREB  
Croatia  
385 1 6141873  
385 1 6141872 (fax)  
turbo@turbo.hr

#### KOYDES TAMIR TICARET VE SANAYI

Sirketi, Sanayi Carsisi  
Dokumculer Sokak No.23  
Eskisehir  
Turkey  
90 222 2277735  
90 222 2173595 (fax)

#### MAGYAR TURBO KFT

Mogyorohegy U7  
P.O.Box 53  
2025 Visegrad  
Hungary  
071 26 398364  
36 26 397253 (fax)  
garrett.stanadyne@elender.hu

#### MOTAIR GmbH

Edsel-Ford-Strasse 21  
50769 Koln  
Germany  
49 2217029-312  
49 2217029-301 (fax)  
b.sanetra@hess-gruppe.de

#### MOTO REMO S.C

ul BISKUPSKA 7  
14-200  
ILAWA  
Poland  
48 089 648 67 67  
48 089 649 22 43 (fax)  
mremo@motoarena.pl

#### NORSK TURBOSERVICE A/S

Moveien 124  
Postboks 63  
3945 Eidanger  
Norway  
47 35511099  
47 35515063 (fax)  
turbosas@online.no

#### REDAT S.P.A.

Via L Calcatelli 3  
10029 Villastellone  
Torino  
Italy  
39 0 11 969 1111  
39 0 11 969 6852 (fax)  
info@redat.com

#### S.C. EUROMOBIL S.R.L.

STR. Ioan Slavici NR. 19 - RO 3900  
3900  
Satu Mare  
Romania  
00 40 61 716217  
00 40 61 710265 (fax)  
euromobil@delphy.ro

#### SCHLUTTER TURBOLADER GmbH

Nuenhofer Allee 82  
50935 koln  
Germany  
49 221 94 0660  
49 221 94 06666 (fax)  
info@turbolader.com

#### SISU AUTO INC. PARTS CENTER AB

Tammi Saarentie 45  
F1-10300 Karjaa  
Finland  
35 890 542011  
35 890 541845 (fax)  
jani.jarvinen@sisuauto.com

#### SPECIAL TURBO

Nechorska 299  
696 21 Prusanky  
Czech Republic  
420 628 374 288  
420 628 374 288 (fax)  
valasek@specialturbo.cz

#### STT SVENSK TURBO TEKNIK AB

PI 7219, Njurundavagen 16A  
S - 86240 Njurunda  
Sweden  
46 60 31111  
46 60 31870 (fax)  
mikael.westin@sttmtec.com

#### TURBO - 3 TRIDIESEL COMERCIAL, S.A.

c/ Buenhumor, 37 - 41  
08902 - Hospitalet De Llobregat  
Barcelona  
Spain  
34 93 3354708  
34 93 2632605 (fax)  
turbo3@turbo3.com

#### TURBO - SCHWEIZ

St. Gallerstrasse 93  
CH - 9202 Gossau  
Switzerland  
41 713 888 988-9  
41 713 888 970 (fax)  
rdmen@klaus-rk.com

#### TURBO HELLAS LTD

421 Athinon Av & Kalpakiou  
12243 Egaleo  
Athens  
Greece  
30 15311719 / 15311720 / 719 / 971 / 972  
30 15311882 (fax)  
turbo98@otenet.gr

### MASTER DISTRIBUTORS

Garrett European Distributors supply the European region with the complete offering of the Garrett Aftermarket productline.

#### TURBO S.C

ul. Tatrzanska 1/5  
60-413  
Poznan  
Poland  
0048 61843 4155  
0048 61843 4506 (fax)  
turbo@poczta.wp.pl

#### TURBO SERVIS

Ul. Dure Danicica 36  
31000 Uzice  
Yugoslavia  
381 31 562233 (or UK 44 01468 904235)  
381 31 562333 (fax)  
turbos@ptt.yu

#### TURBO TECHNICS LTD

17 Galowhill Rd  
Brackmills  
Northampton  
United Kingdom  
NN4 7PL  
44 (0)1604 764005  
44 (0)1604 769668 (fax)  
keith@turbotechnics.com

#### TURBOTEKNIikka OY

Valuraudantie 4  
700  
Helsinki  
Finland  
357 9 350 5270  
358 9 350 52 777 (fax)  
jukka.kulovesi@turbotekniikka.fi

#### TURBO TUNISE SARL

19 Rue 9006 Dubosville (GP1)  
2023 Sidi Fathallah  
Tunis  
Tunisia  
21 61 397660  
21 61 397564 (fax)

#### TURBO TWINS OEG

2320 Schwechat  
Innerbergstrasse 1-3  
Austria  
43 1706 4555  
43 1706 455511 (fax)  
office@turbotwins.at

#### TURBOMASTER S.L.

Mar Mediterraneo, 1 - Nave 7  
28830 San Fernando de Henares  
Madrid  
Spain  
34 91 656 9273 / 656 92 88  
34 91 656 93 97 (fax)  
ajcamarasaltas@turbomaster.com

#### TURBOS HOET NDEERLAND BV

Hermesweg 13  
3741 GP Baarn  
Holland  
31 3 55420241  
31 3 55422453 (fax)  
dirk.spillebeen@turbos-hoet.nl

#### TURBOS HOET PARTS & REVISIE N.V.

leperstraat 144a  
B- 8830 Hooglede  
Belgium  
32 51700691  
32 51702812 (fax)  
joris.ampe@turbos-hoet.be

#### TURBOS HOET PIECES & VEHICULES S.A.

Rue du Dronckaert 15 Bis  
59223 Roncq  
France  
33 3 20762660  
33 3 20762661 (fax)  
filiep.vlaminck@turbos-hoet.fr

#### UNIVEX AUTOTEILE

Nording 15  
76761  
Rulzheim  
Germany  
49 7272 91 99 04  
49 7272 76752/774370 (fax)  
daniel@univex.de

#### RUSTURBO

Moscow  
Russia

**Garrett®**

*PERFORMANCE PRODUCTS*

**Garrett**

**TURBOCHARGERS**



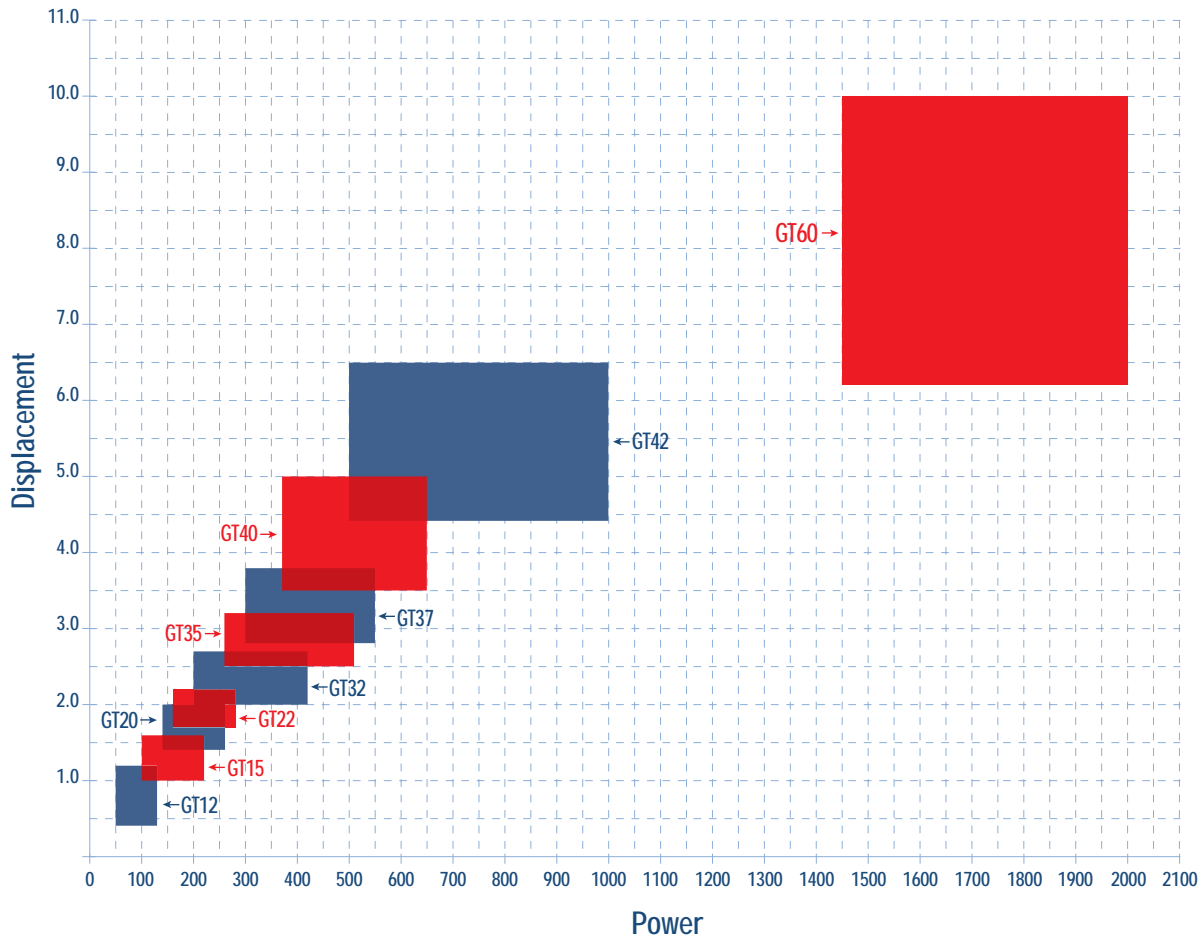

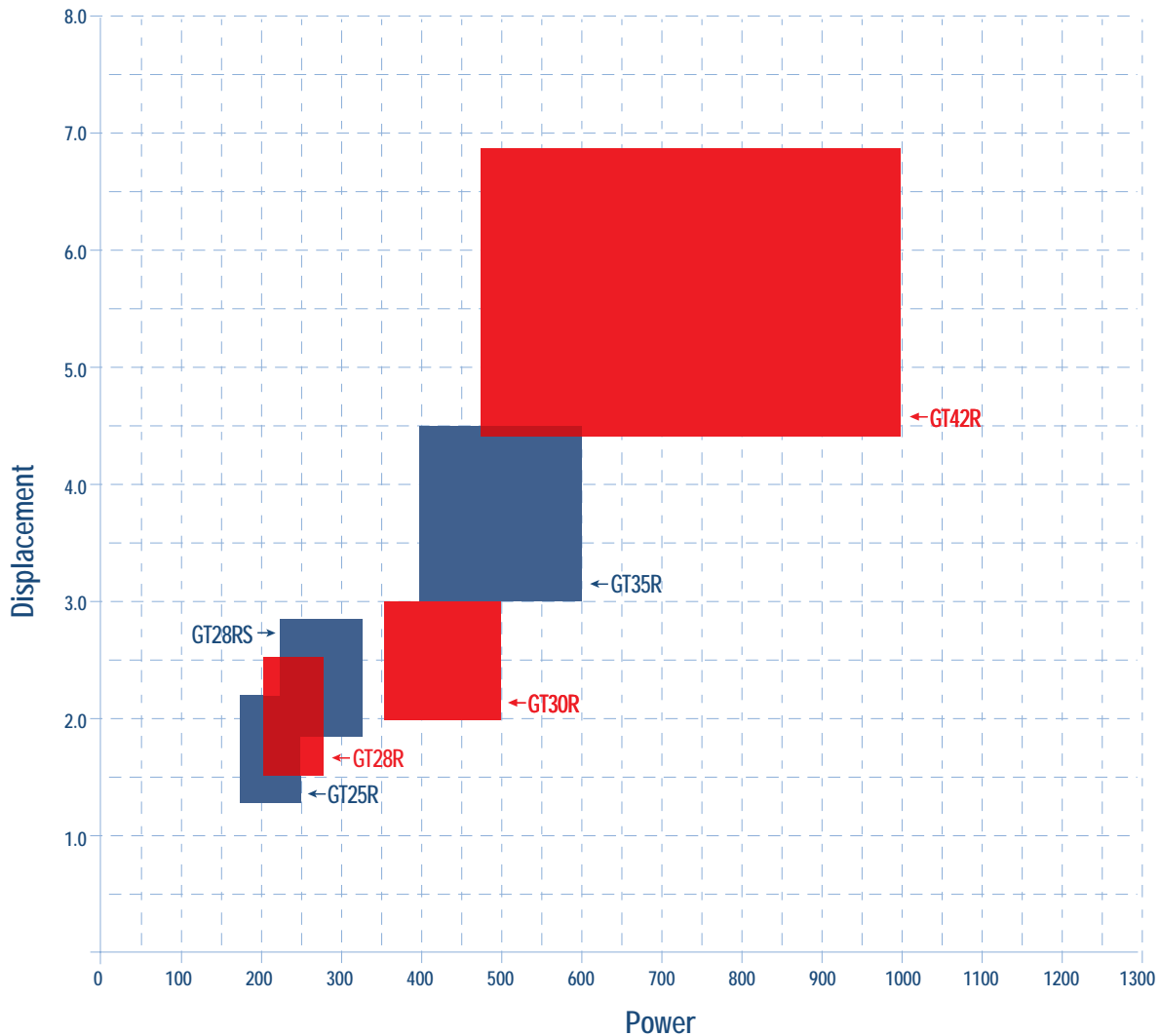

### How to know you are selecting a true Garrett Ball Bearing Turbocharger

Garrett Ball Bearing Turbochargers always end with an "R" as in GT28R. The R denotes the "rolling" element found in the single cartridge, dual ball bearing design Garrett uses on all GT Ball Bearing Turbochargers contained in the Performance Products Catalog.

# **BALL BEARING**

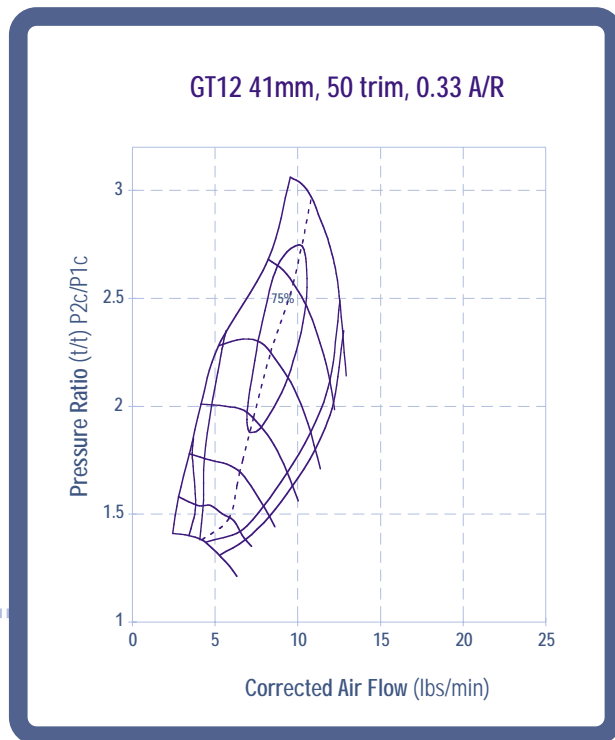
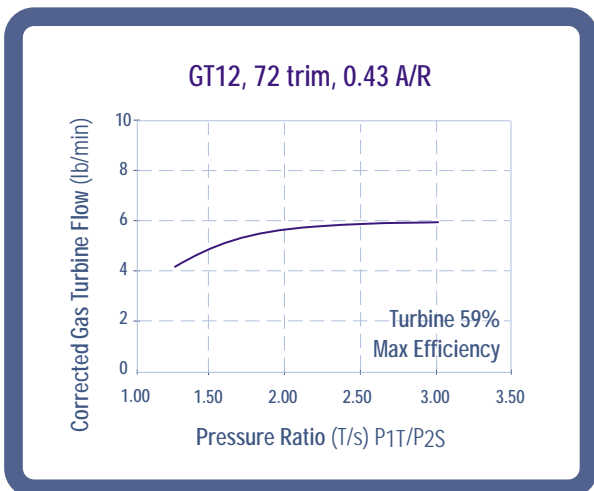
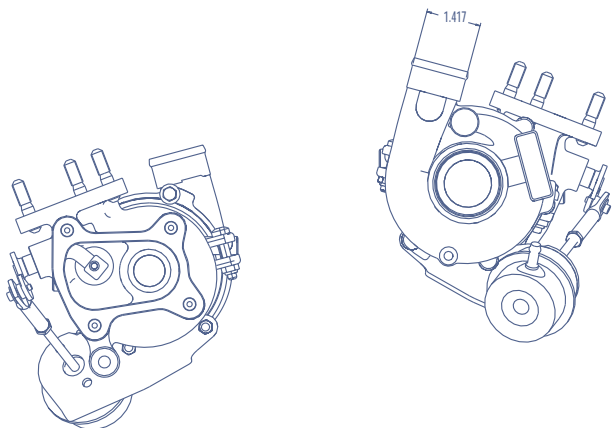

**POWERSHIFT**

Horsepower 50 - 130  
Displacement .4L - 1.2L

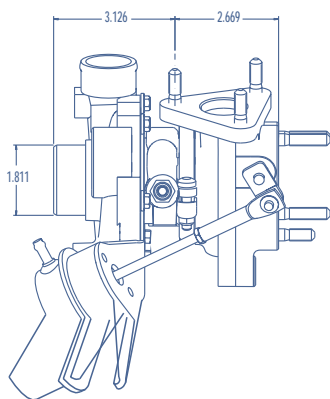

			COMPRESSOR			TURBINE			
	Turbo	CHRA	Wh Dia	Trim	A/R	Wh Dia	Trim	A/R	Type
<b>GT12</b>	708001-1	708247-7	41mm	50	0.33	35.5mm	72	0.43	Wastegated

**Watercooled CHRA**

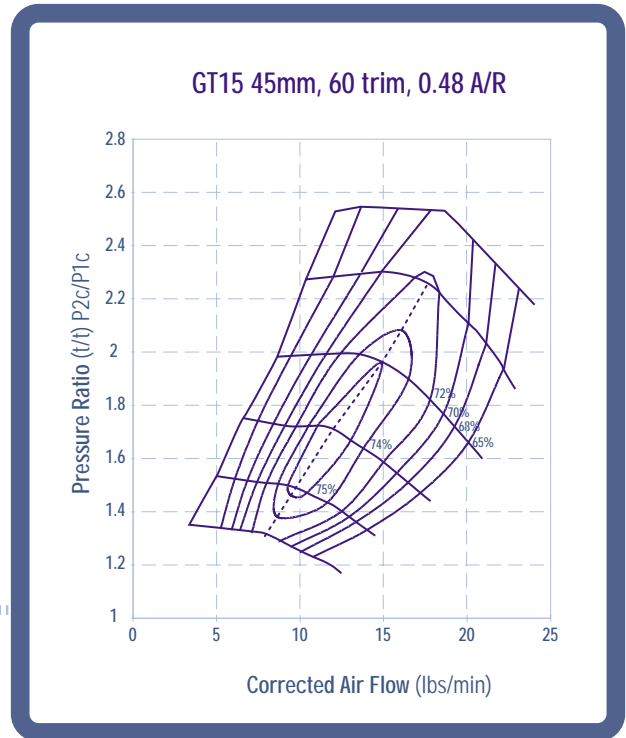
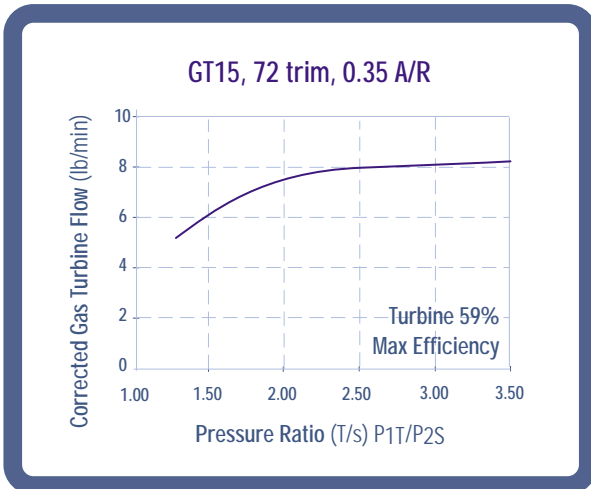
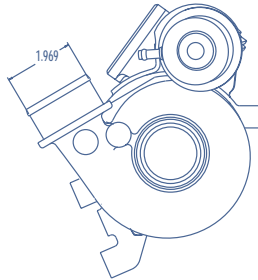
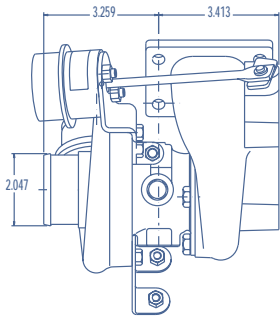

**POWERSHIFT**

Horsepower 100 - 220  
Displacement 1.0 - 1.6L

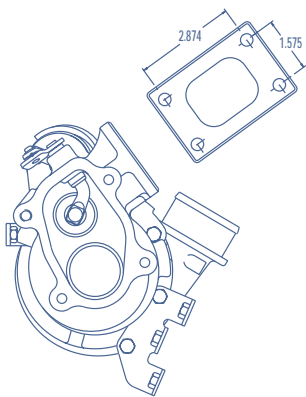

	COMPRESSOR			TURBINE					
	Turbo	CHRA	Wh Dia	Trim	A/R	Wh Dia	Trim	A/R	Type
<b>GT15</b>	466755-3	431876-93	45mm	60	0.48	41.2mm	72	0.35	Wastegated

**Watercooled CHRA**

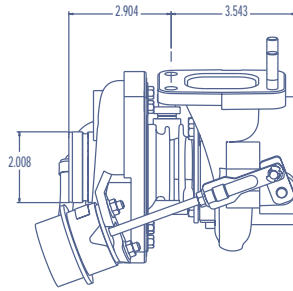
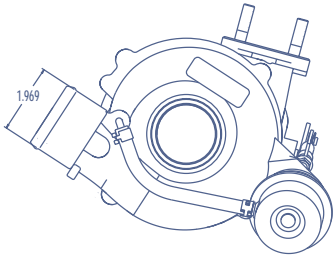

GT20 56mm, 55trim, 0.53 A/R

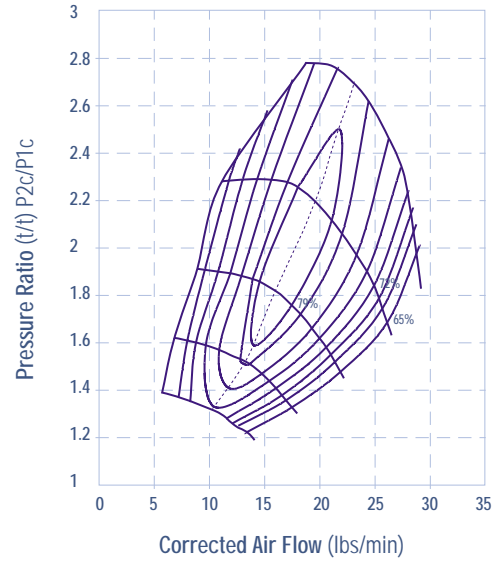

GT20, 72 trim, 0.46 A/R

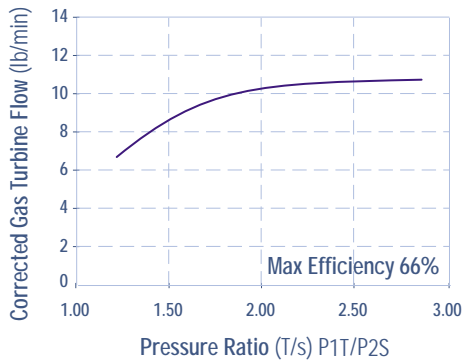

**POWERSHIFT**

Horsepower 140 - 260  
Displacement 1.4 - 2.0L

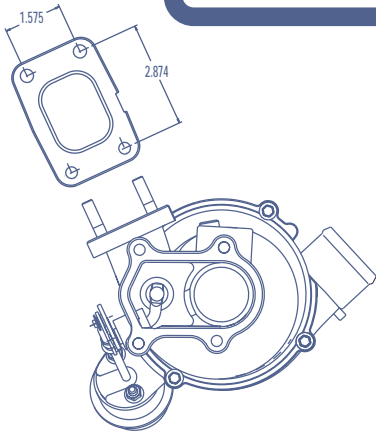

**GT20**

		COMPRESSOR			TURBINE			
Turbo	CHRA	Wh Dia	Trim	A/R	Wh Dia	Trim	A/R	Type
454126-2	433289-96	56mm	55	0.53	47mm	72	0.46	Wastegated

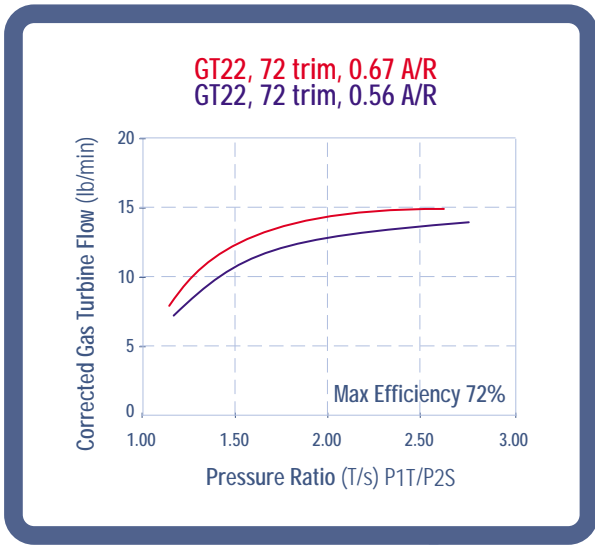
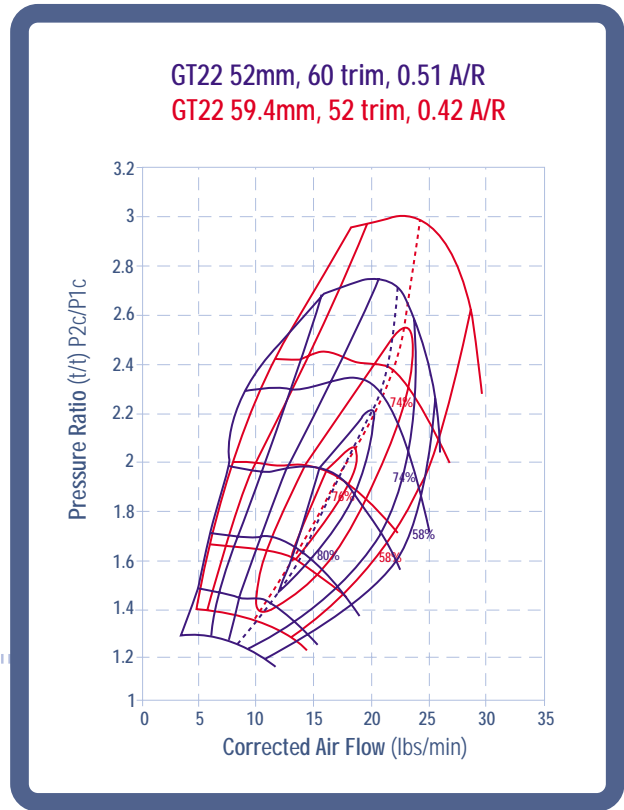
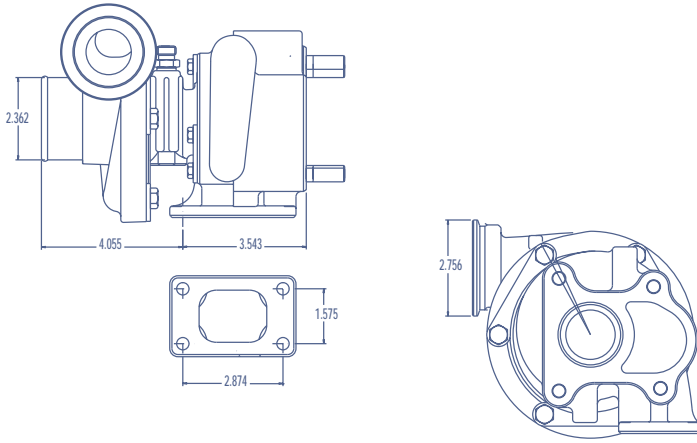

**POWERSHIFT**

Horsepower 160 - 280  
Displacement 1.7 - 2.2L

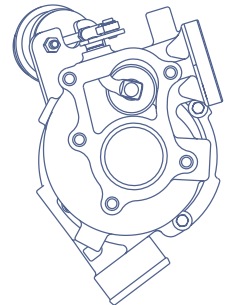

		COMPRESSOR			TURBINE				
Turbo	CHRA	Wh Dia	Trim	A/R	Wh Dia	Trim	A/R	Type	
GT22	452187-6	451298-6	52mm	60	0.51	50.3mm	72	0.67	Wastegated
	452214-3	451298-9	59.4mm	52	0.42	50.3mm	72	0.56	Free Float
		TURBINE OPTION							
		436313-6		72	0.67	Wastegated			
		451503-1		72	0.56	Free Float			

# GT25R Ball Bearing

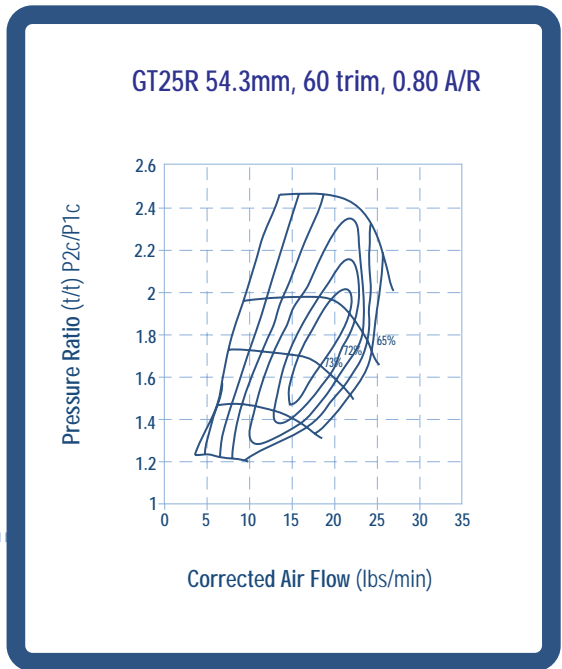
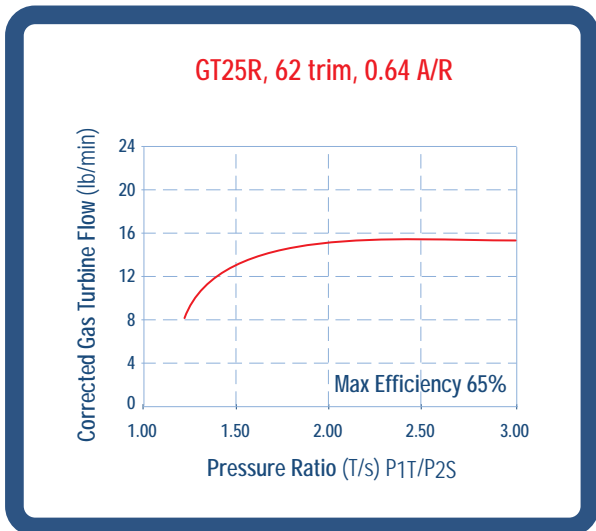
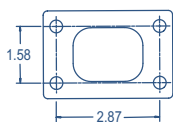
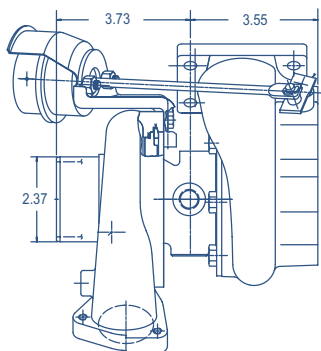

**POWERSHIFT**  
Horsepower 170 - 250  
Displacement 1.4 - 2.2L

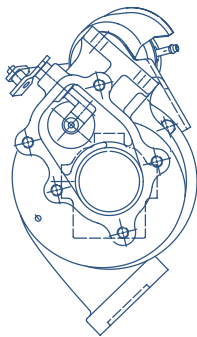

**GT25R** Turbo CHRA  
471171-3 446179-24

C O M P R E S S O R			T U R B I N E			
Wh Dia	Trim	A/R	Wh Dia	Trim	A/R	Type
54.3mm	60	0.80	53mm	62	0.64	Wastegated

**Watercooled CHRA**

## GT28R Ball Bearing

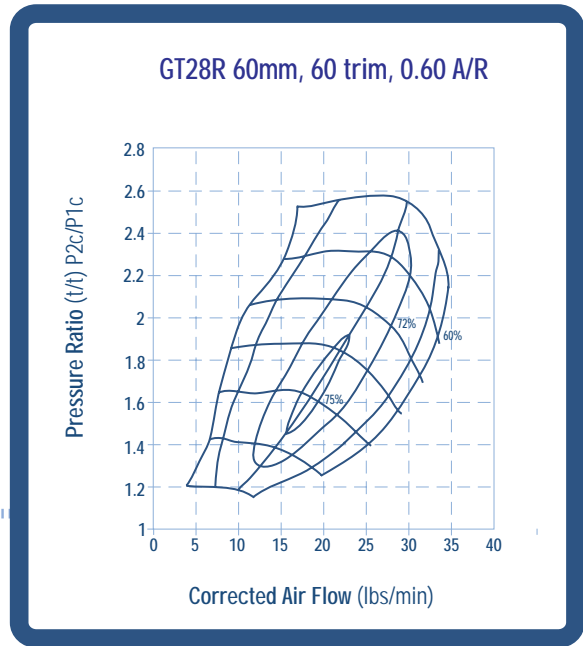
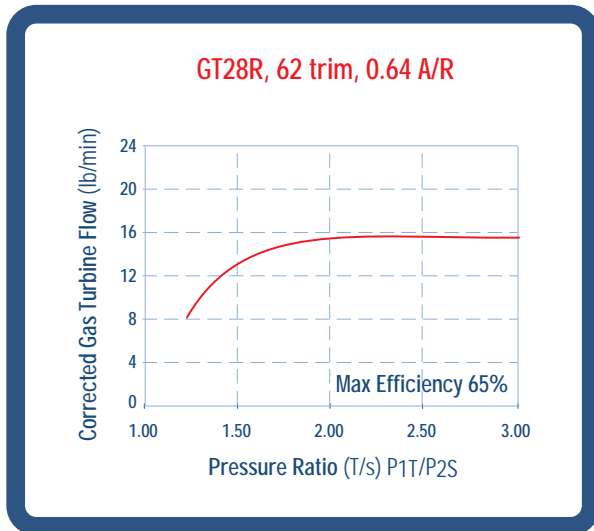
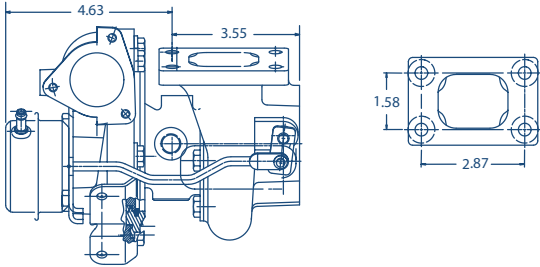

**POWERSHIFT**

Horsepower 200 - 280  
Displacement 1.6 - 2.5L

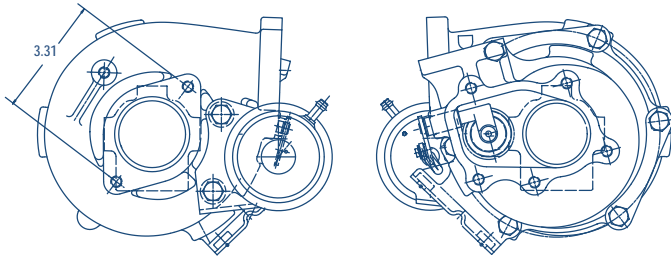

Turbo	CHRA	COMPRESSOR			TURBINE				
		Wh Dia	Trim	A/R	Wh Dia	Trim	A/R	Type	
GT28R	466541-1	446179-12	60mm	60	0.60	53mm	62	0.64	Wastegated

Watercooled CHRA



# GT28RS

## The Disco Potato Ball Bearing

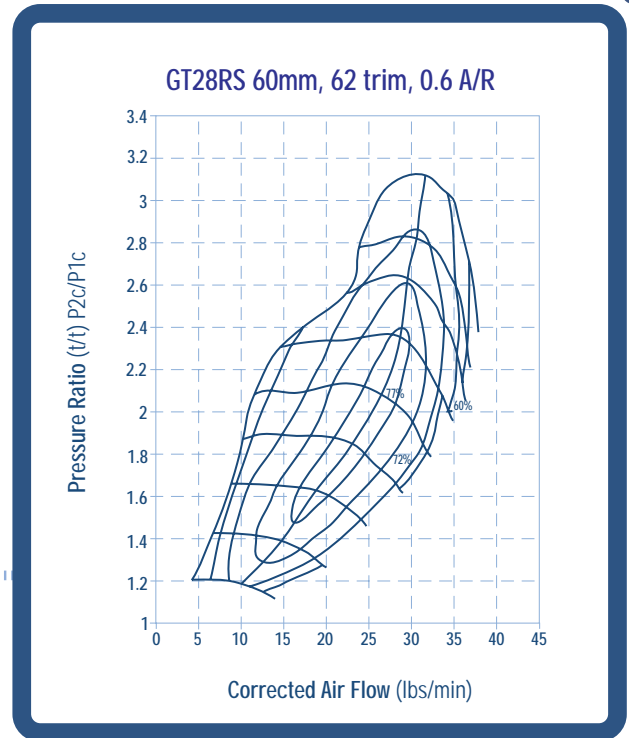
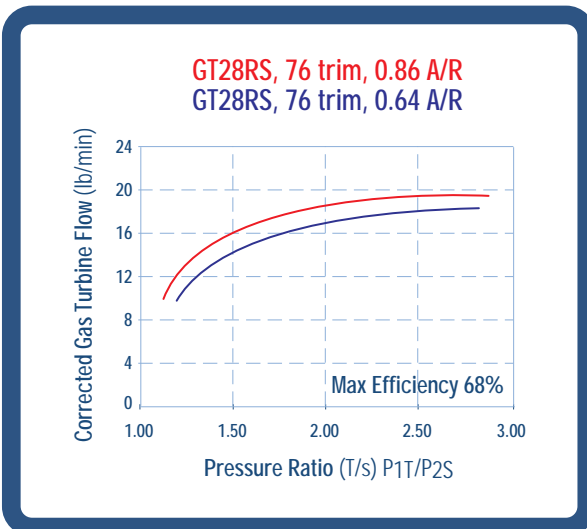
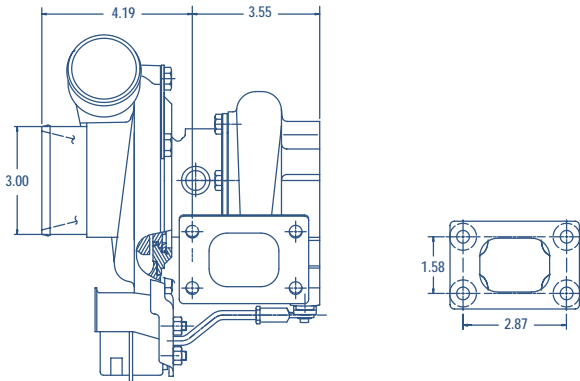

**POWERSHIFT**  
Horsepower 250 - 320  
Displacement 1.8 - 2.7L

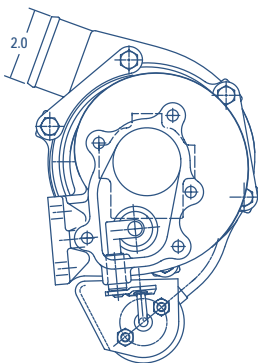

Turbo	CHRA
<b>GT28RS</b> 739548-1	446179-66

COMPRESSOR			TURBINE			
Wh Dia	Trim	A/R	Wh Dia	Trim	A/R	Type
60mm	62	0.60	53.85mm	76	0.86	Wastegated
TURBINE OPTION						
			53.85mm	76	0.64	Wastegated

430609-230

Watercooled CHRA

The 700382-12 GT30R is a customizable Garrett ball bearing GT turbo that is packaged without the turbine housing. (It includes a CHRA and compressor housing.) Either 740902-1 or 740902-2 turbine housing kits are available.

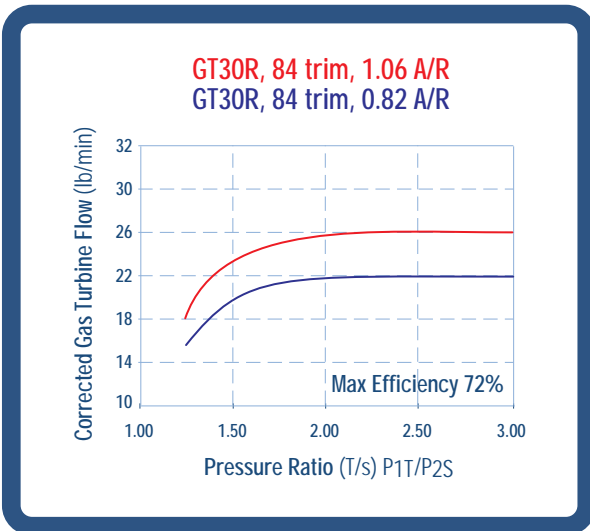
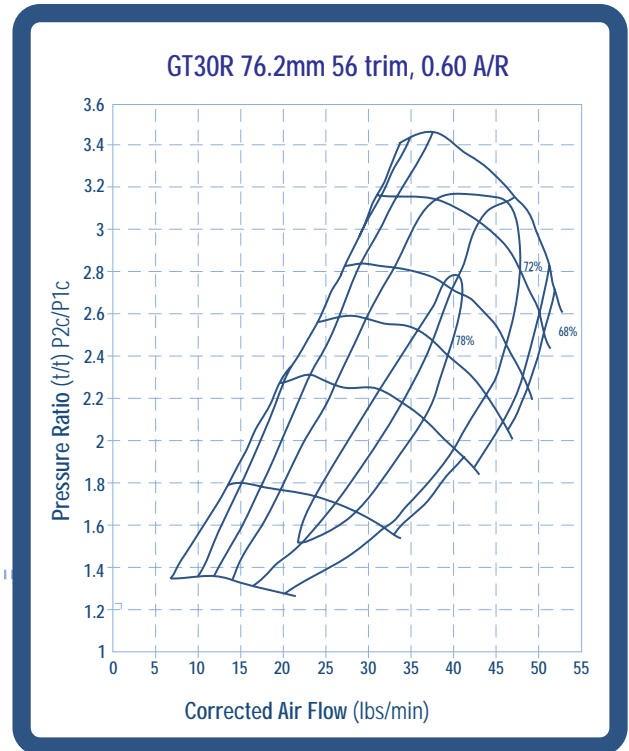
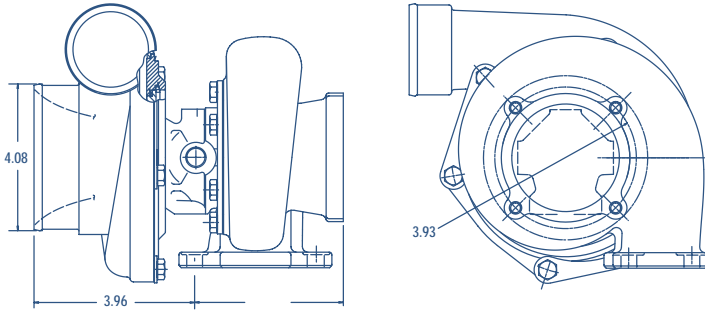

**POWERSHIFT**  
Horsepower 350 - 500  
Displacement 2.0 - 3.0L

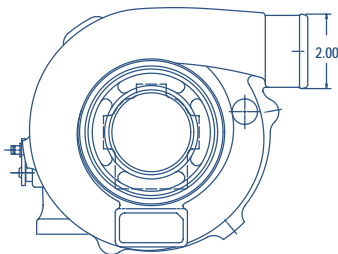

**GT30R**

Turbo	COMPRESSOR			TURBINE WHEEL			
	Wh Dia	Trim	A/R	Wh Dia	Trim	A/R	Type
700382-12	76.2mm	56	0.60	60mm	84	---	---

TURBINE HSG KITS				
740902-1	---	---	1.06	Free Float
740902-2	---	---	0.82	Free Float

The turbine housing kits include turbine housing, clamps, bolts, and turbine inlet gasket. The housing is designed with T3 inlet flanges and a 4 bolt outlet.

**Watercooled CHRA**

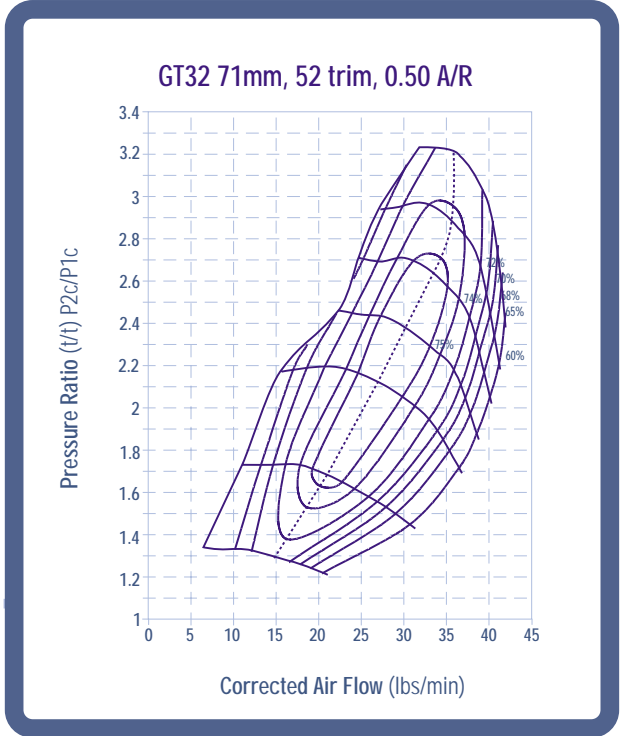
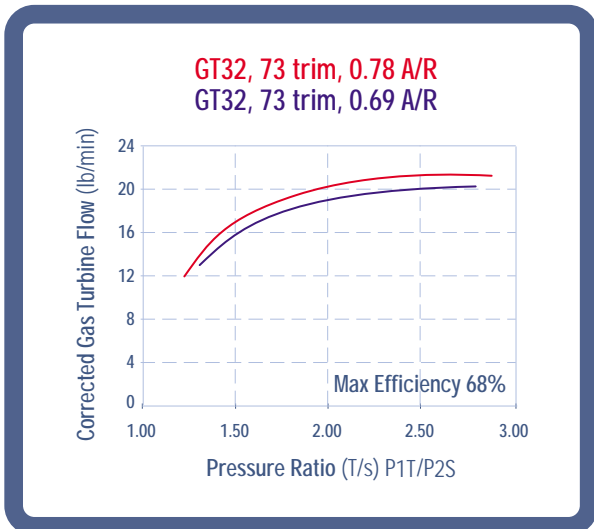
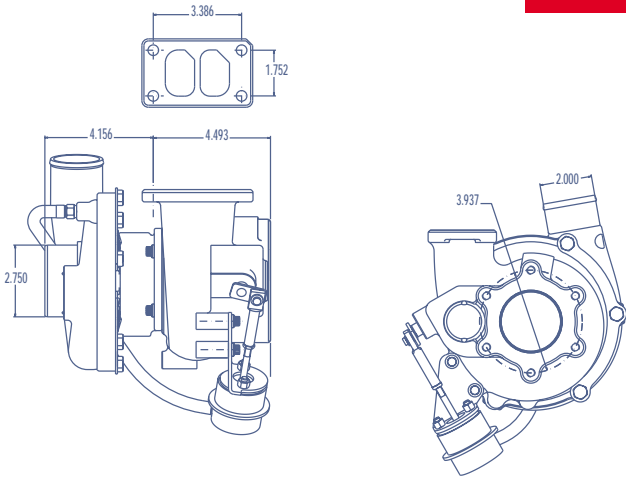

**POWERSHIFT**  
 Horsepower 200 - 420  
 Displacement 2.0 - 2.7L

Turbo	CHRA	COMPRESSOR			TURBINE				
		Wh Dia	Trim	A/R	Wh Dia	Trim	A/R	Type	
<b>GT32</b>	452203-1	436058-3	71mm	52	0.50	64mm	73	0.78	Wastegated
TURBINE OPTION									
						451225-26	73	0.78	Free Float
						435066-32	73	0.69	Wastegated

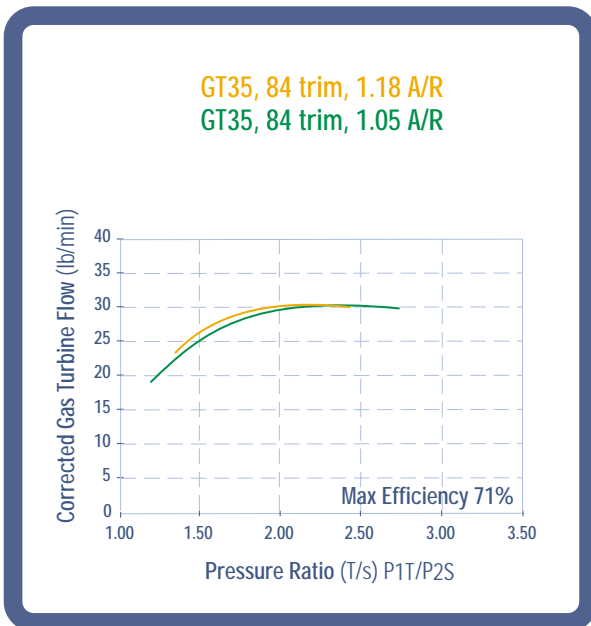
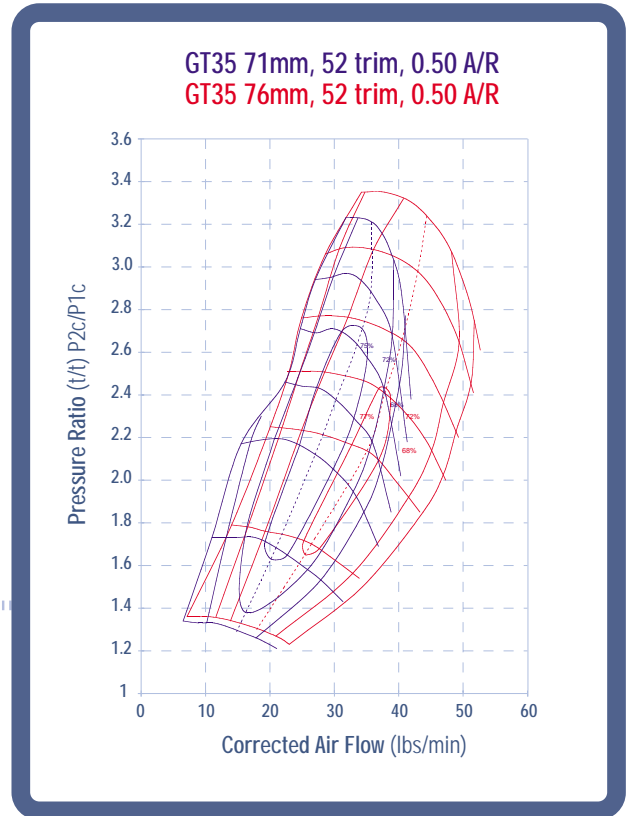
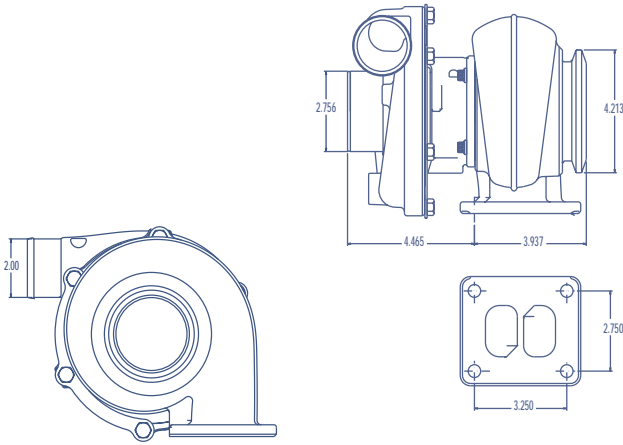

**POWERSHIFT**  
Horsepower 260 - 510  
Displacement 2.5L - 3.2L

Turbo	CHRA	COMPRESSOR			TURBINE				
		Wh Dia	Trim	A/R	Wh Dia	Trim	A/R	Type	
GT35	731413-1	436058-11	71mm	52	0.50	68mm	84	1.18	Free Float
		COMPRESSOR OPTION			TURBINE OPTION				
		731428-1	76mm	52	0.50	714690-13	84	1.05	Free Float

# GT35R Ball Bearing

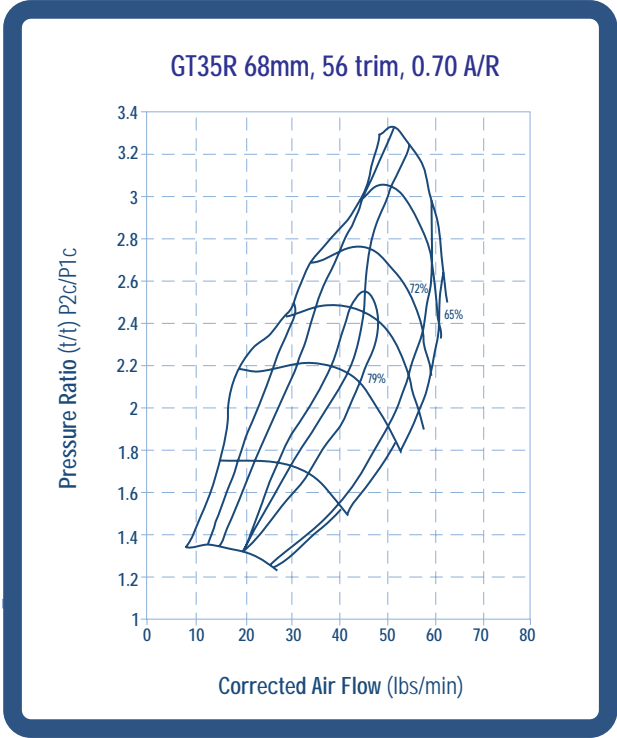
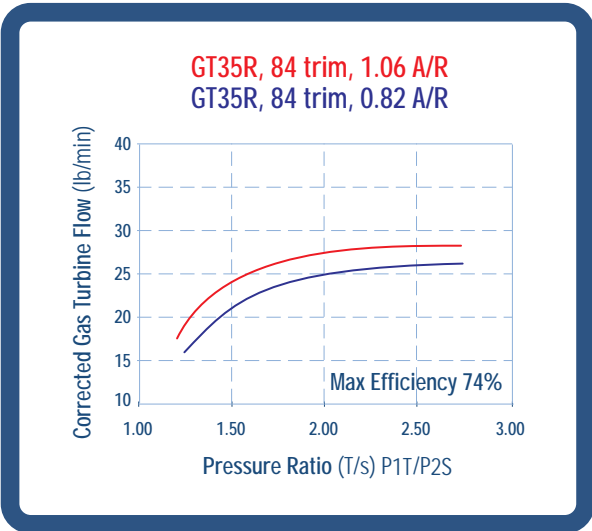
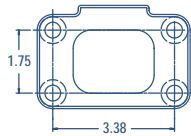
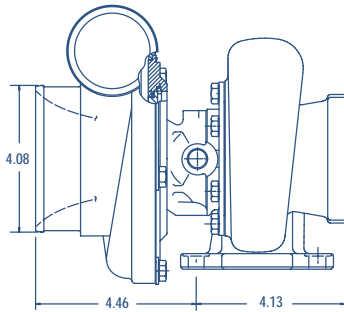

**POWERSHIFT**  
Horsepower 400 - 600  
Displacement 3.0 - 4.5L

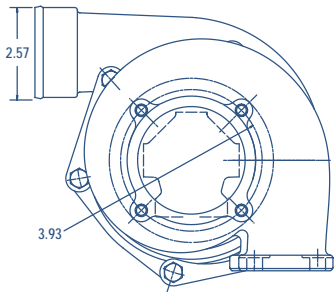

**GT35R**

Turbo	CHRA
714568-1	706451-5
714568-2	706451-5

COMPRESSOR			TURBINE			
Wh Dia	Trim	A/R	Wh Dia	Trim	A/R	Type
82mm	56	0.70	68mm	84	1.06	Free Float
82mm	56	0.70	68mm	84	0.82	Free Float

**Watercooled CHRA**

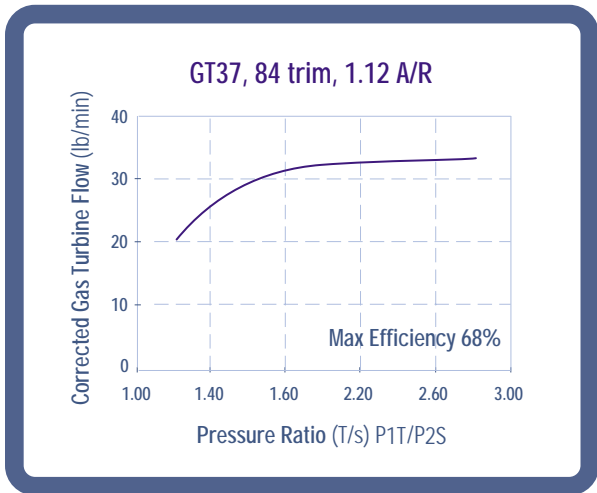
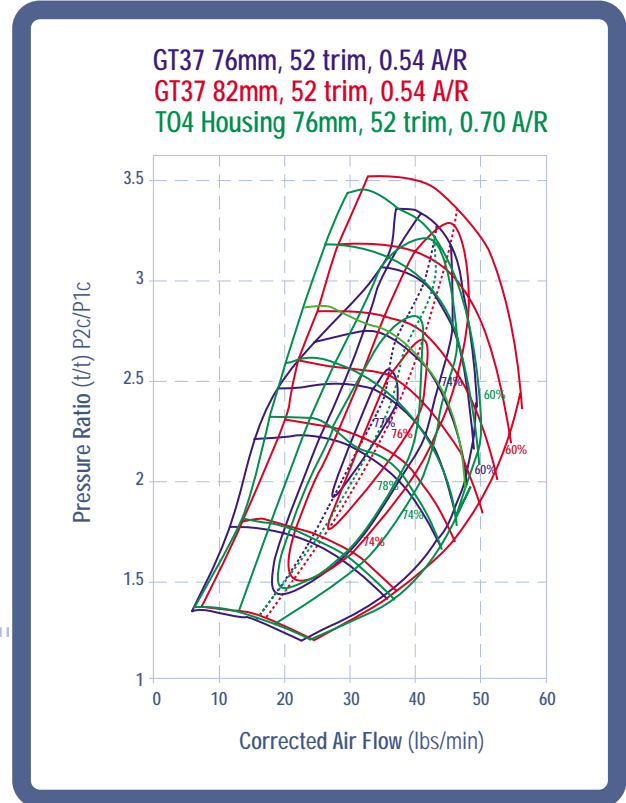
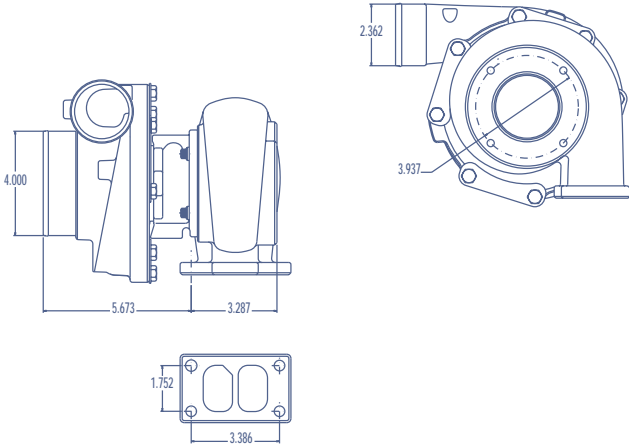

**POWERSHIFT**

Horsepower 300 - 550  
Displacement 2.8 - 3.8L

Turbo	CHRA	COMPRESSOR			TURBINE			
		Wh Dia	Trim	A/R	Wh Dia	Trim	A/R	Type
GT37 452159-1	436085-1	76mm	52	0.54	72.5mm	84	1.12	Free Float
452159-3	436085-5	82mm	52	0.54	72.5mm	84	1.12	Free Float

COMPRESSOR OPTION				
731428-2	76mm	52	0.70	
731428-3	82mm	52	0.54	

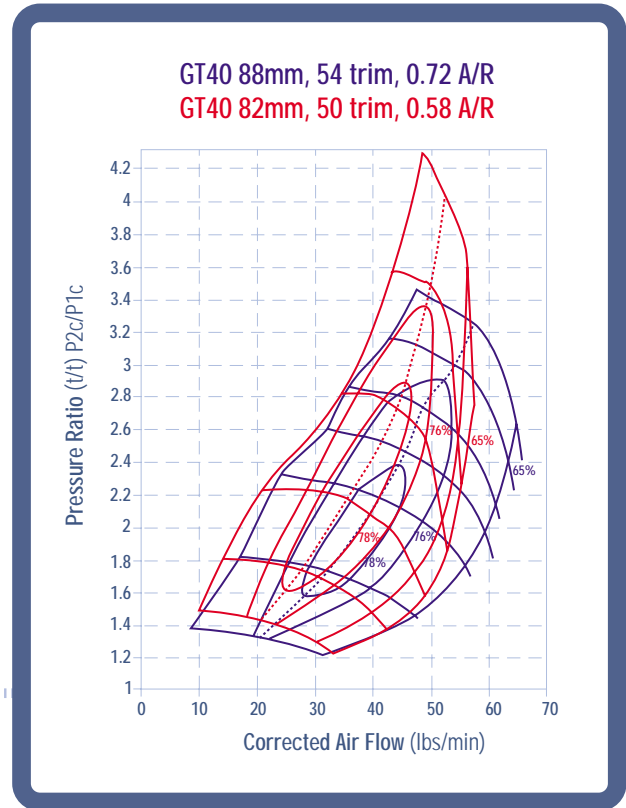
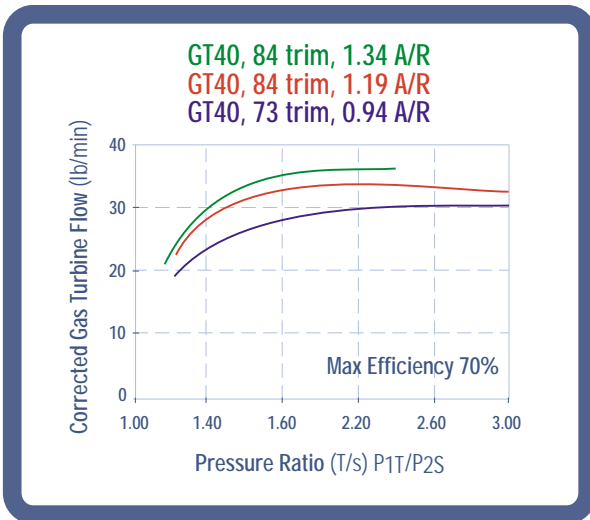
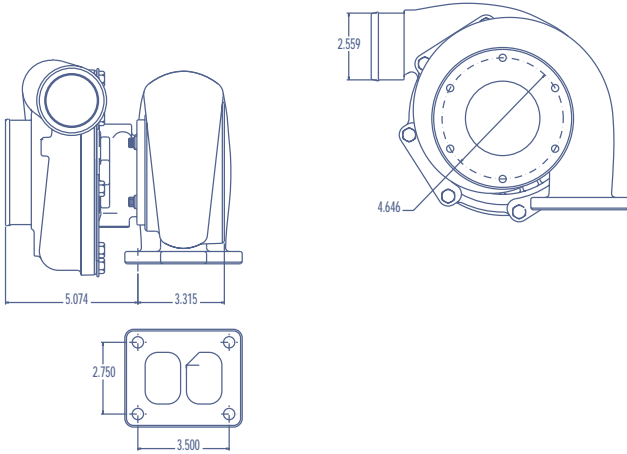

**POWERSHIFT**

Horsepower 370 - 650  
Displacement 3.5 - 5.0L

Turbo	CHRA	COMPRESSOR			TURBINE			
		Wh Dia	Trim	A/R	Wh Dia	Trim	A/R	Type
<b>GT40</b> 452232-5	449739-10	82mm	50	0.58	77mm	73	0.94	Free Float
703457-2	449739-34	88mm	54	0.72	77mm	84	1.34	Free Float
TURBINE OPTION								
					434309-88	84	1.19	Free float

Ball Bearing Option Available

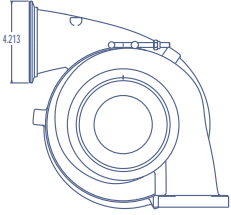

**POWERSHIFT**

Horsepower 500 - 1000  
Displacement 4.4L - 6.5L

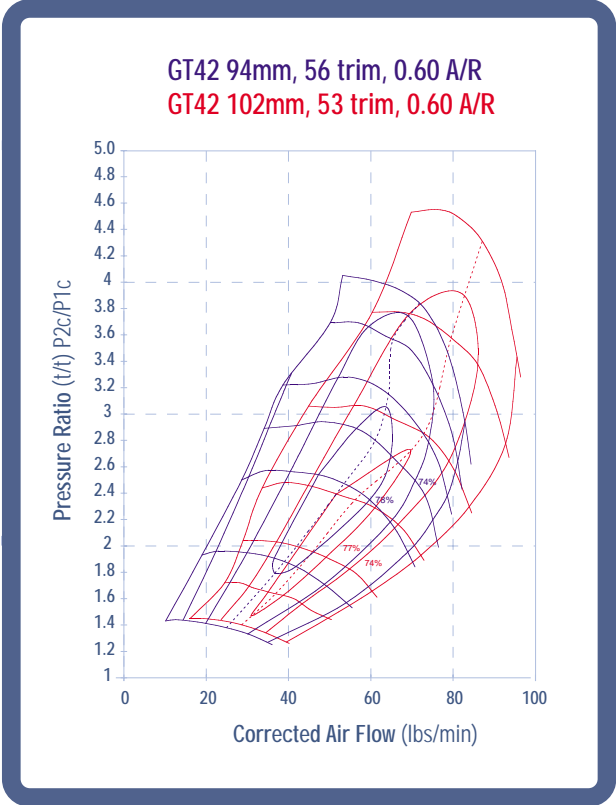
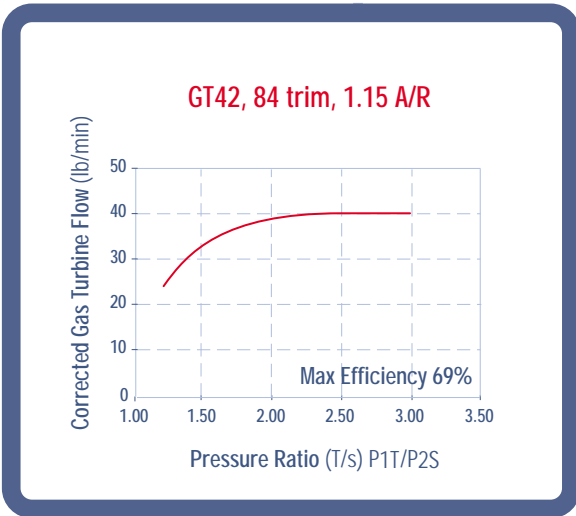

Turbo	CHRA	COMPRESSOR			TURBINE				
		Wh Dia	Trim	A/R	Wh Dia	Trim	A/R	Type	
GT42	731376-1	712402-7	94mm	56	0.60	82mm	84	1.15	Free Float
	731376-2	712402-8	102mm	53	0.60	82mm	84	1.15	Free Float

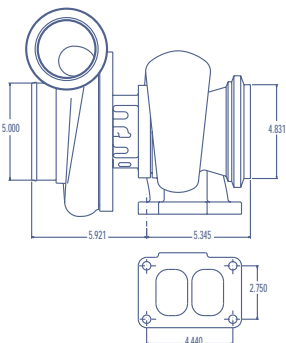

## GT42R Ball Bearing CHRA Options

451888-9	94mm	56	82mm	84
451888-11	102mm	53	82mm	84



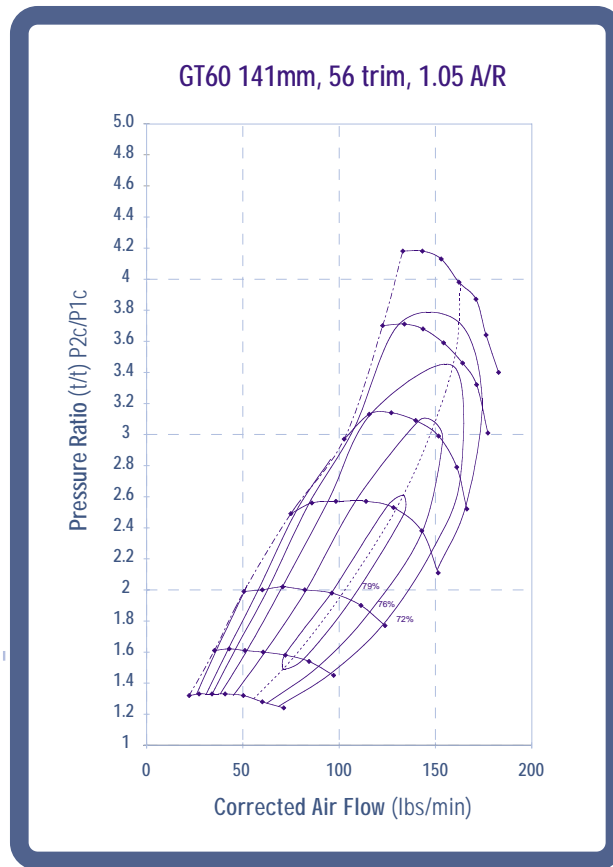
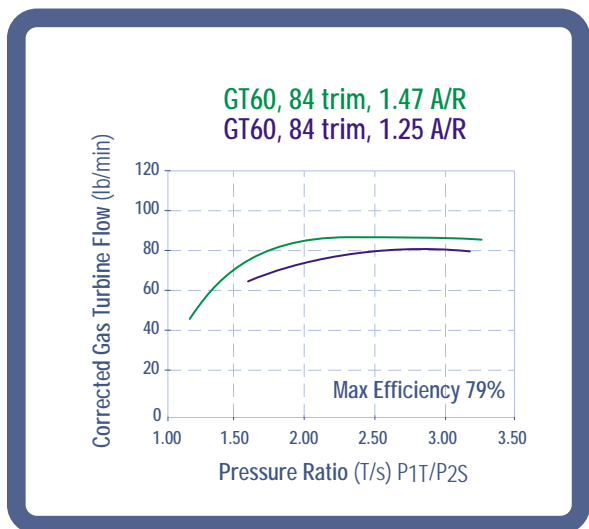
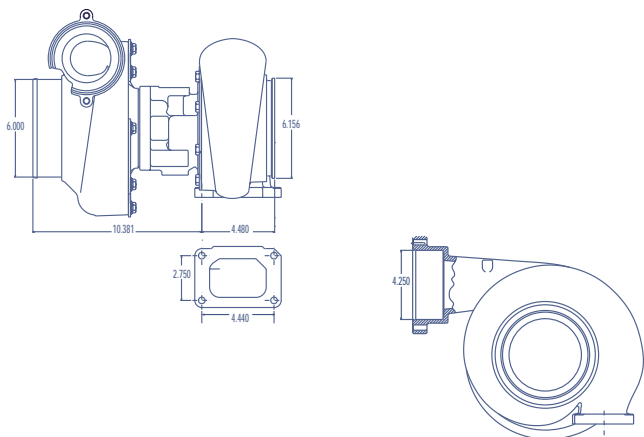

**POWERSHIFT**

Horsepower 1450 - 2000  
Displacement 6.2L - 10L

		COMPRESSOR			TURBINE				
	Turbo	CHRA	Wh Dia	Trim	A/R	Wh Dia	Trim	A/R	Type
<b>GT60</b>	731377-1	730496-1	141mm	56	1.05	130mm	84	1.47	Free Float
		<b>TURBINE OPTION</b>							
						441319-97	84	1.25	Free Float

In addition to the GT products contained in the 2002 Garrett Performance catalog, Garrett provides coverage for a broad selection of traditional turbocharger models. These models are serviced with two product segments.

#### Component Parts

The component product segment provides the ability to service and/or make available component parts to Garrett customers who service performance turbochargers that have failed. This product also provides the ability to assemble standard or hybrid turbocharger or cartridge configurations.

#### Traditional Assemblies

The traditional assembly product segment is comprised of turbocharger and cartridge assemblies that have been applied to a broad spectrum of existing performance applications.

These components and/or assemblies may provide coverage for the following models:

---

BTG55	T28	TA31	TBB25	TMF55	TV92
BTV75	T300	TA34	TB03	TP38	TV94
BTV85	T31	TA45	TB05	TV45	TV95
BTW75	T350	TA51	TB06	TV51	TW41
T2	T35	TA03	TBP404	TV61	TW81
T3	T45	TB02	TC43	TV63	UTG75
T4	T51	TB03	TC04	TV70	UTV71
T6	T52	TB22	TH08A	TV71	UTV75
T12	T04	TB25	TL75	TV75	UTV94
T18A	T04B	TB28	TL92	TV80	UTV95
T25	T04E	TB34	TM54	TV81	UTW75
	T04S	TB41	TMF51	TV84	UTW83

---

*Contact Your Authorized Garrett Distributor for technical data and product availability.*

**Garrett®**

***PERFORMANCE PRODUCTS***

**Garrett**

***ANCIILLARY PRODUCTS***

**High-Performance Stainless Steel Wastegate Assemblies:** Garrett Performance Products is pleased to be the exclusive distributor of TiAl wastegate & blowoff valve assemblies. All wastegate assemblies are constructed with stainless steel valves and valve bodies. Actuator housings are CNC machined billet aluminum, with an optimal actuator to valve ratio of 2.2:1 for maximum flow capacity. The units are also designed with high temperature Nomex diaphragms and oxidation resistant Super Alloy components.

Valve Size (diameter)	Part Number	Spring Rate (bar/psig)
38mm	721490-0002	.36/5.2
	721490-0003	.47/6.8
	721490-0004	.59/8.6
40mm	721491-0004	.55/8.0
	721491-0005	.66/9.6
	721491-0006	.77/11.2
46mm	721492-0005	.60/8.7
	721492-0006	.70/10.2
	721492-0007	.80/11.6

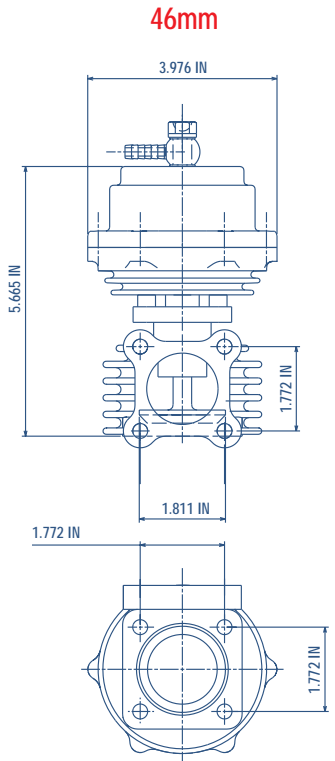
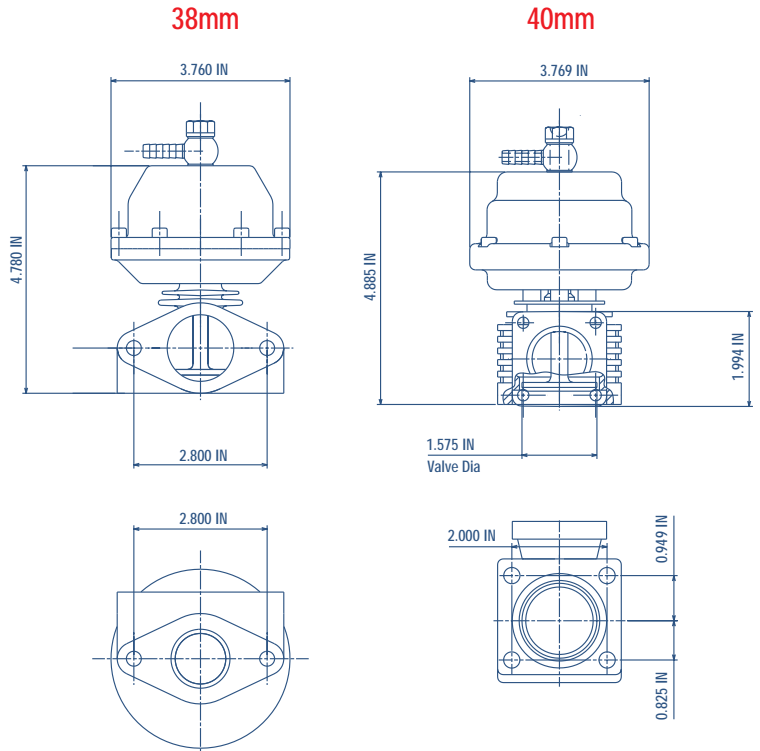

### Stainless Steel CNC Wastegate Flanges

Model	Part Number	Type	Configuration
38mm	716463-0001	Outlet Flange	2 x thru hole
	716463-0002	Inlet Flange	2 x M8-1.25
40mm	716466-0001	Inlet Flange	4 x M8-1.25
	716464-0001	Outlet Flange	4 x thru hole
46mm	716465-0001	Inlet or Outlet Flange	4 x thru hole

## BLOW-OFF VALVE

**50mm Compressor Blow Off Valve Assemblies:** The Garrett (TiAl) Blow-Off valve design is the result of extensive development and testing. The 50mm compressor bypass valve is a vital component of any turbocharged blow-through induction system. This custom TiAl manufactured blow-off valve will improve throttle (time to boost) response as well as help relieve the damaging effects of compressor “surge loading”. The CNC machined housings are available in several high luster anodized colors.

Note: Blow-off Valve Assemblies include fitting and V-band clamp.

### Blow-Off Valve

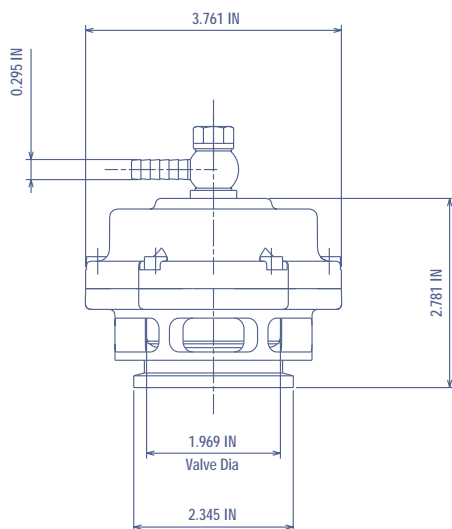

Part Number	Color
714341-0001	Red
714341-0002	Blue
714341-0003	Gray
714341-0004	Violet
714341-0005	Machined Aluminum

### Blow-off Valve Flanges

Part Number	Material
722783-0001	Aluminum (6061)
722783-0002	Steel (1018)
722783-0003	Stainles Steel (304L)

### Blow-Off Valve Flange

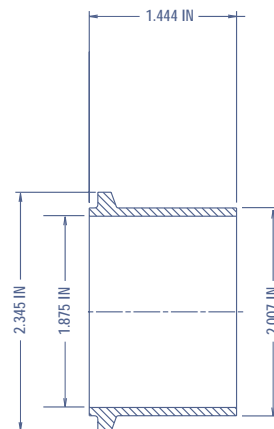

The Garrett Performance Intercoolers (also known as Charge Air Coolers) work together with the turbocharger as a part of the total induction system. When air is compressed in the turbocharger it gains a great deal of heat. The heated air has lower oxygen density and therefore is not able to produce as much energy when fed into the cylinders. The job of the intercooler is to remove heat added by compression in the turbocharger and in turn promote more thorough combustion yielding more power, less emissions, and greatly reducing detonation.

Performance estimates made under the following conditions:

charge air inlet temperature = 250 degrees F

pressure ratio = 2.0 (approximately 14.7psi)

cooling air temperature = 75 degree F

cooling air flow rate set with 1 in. H<sub>2</sub>O pressure drop

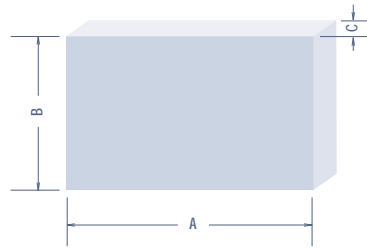

### AIR TO AIR INTERCOOLER CORES (tube-header construction)

Part Number	CORE ENVELOPE			Weight (lbs.)	Estimated Power (hp)	Charge Air $\Delta P$ (psi)	Charge Air $\Delta T$ (F)	Effectiveness (%)
	A Hot Flow Length (in)	B No Flow Length (in)	C Cold Flow Length (in)					
485257-6001	24	15.5	2.2	29.4	450	1	138	79
485643-6003	26	18.5	2.8	33	600	0.94	142	81
485740-6002	26.5	12	2.8	15.3	400	1	141	80
485980-6002	30.3	16	2.8	21.8	480	0.9	150	86
487085-6002	20	11	3	15.2	420	1	119	68

(continued)

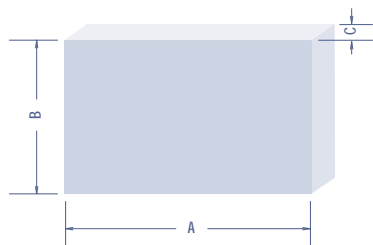

### AIR TO AIR INTERCOOLER CORES (bar-plate construction)

Part Number	CORE ENVELOPE			Weight (lbs.)	Estimated Power (hp)	Charge Air $\Delta P$ (psi)	Charge Air $\Delta T$ (F)	Effectiveness (%)
	A Hot Flow Length (in)	B No Flow Length (in)	C Cold Flow Length (in)					
713372-0001	16	10.3	2.8	8.8	320	0.96	123	70
713447-0001	16	5.4	2.8	5	205	1	109	62
703517-6001	6	11.7	3	7.1	175	0.2	92	53
703517-6002	8	11.7	3	8	200	0.29	104	60
703517-6003	10	12	3	8.7	225	0.36	113	65
703518-6001	12	12	3	9.8	300	0.49	115	66
703518-6002	14	12	3	10.8	325	0.57	118	67
703518-6003	16	12	3	12.6	350	0.64	121	69
703518-6004	18	12	3	13.9	375	0.95	126	72
703518-6005	24	12	3	18.5	450	0.79	127	73
703519-6001	6	12	3.5	7.3	150	0.12	99	57
703519-6002	8	11.7	3.5	8.9	185	0.14	104	59
703519-6003	10	11.7	3.5	10.6	265	0.32	105	60
703520-6001	12	12	3.5	11.8	300	0.31	113	65
703520-6002	14	12	3.5	13.4	350	0.42	115	65
703520-6003	16	12	3.5	15.3	400	0.52	112	64
703520-6004	18	12	3.5	16.4	465	0.89	117	67
703520-6005	24	12	3.5	21.1	500	1	127	72
486827-6002	24	12	4	25.1	520	0.82	129	74
700618-6001	16	10	4	24.4	400	0.42	105	60
703521-6001	6	12.4	5	9.2	150	0.1	90	51
703521-6002	8	11.7	4.5	11.4	165	0.08	100	57
703521-6003	10	11.7	4.5	13.3	225	0.16	112	64
703522-6001	12	12	4.5	14.4	275	0.17	120	69
703522-6002	14	12	4.5	16.6	300	0.23	125	72
703522-6003	16	12	4.5	18.5	345	0.29	124	71
703522-6004	18	12	4.5	20.2	420	0.45	120	69
703522-6005	24	12	4.5	26.6	480	0.65	129	74
701596-6001	27.8	12.8	5	31.4	575	0.42	132	76

**Garrett®**

*PERFORMANCE PRODUCTS*

**Garrett**

**TECHNICAL INFORMATION**



The following section includes information that is found in several reference books. The Garrett Engineering team is including this information as a quick reference to help you match a Garrett turbocharger to your engine. Examples are incorporated to help walk you through the matching process.

### Turbine Maps

**1. Turbine Expansion Ratio** – The degree of exhaust expansion as it passes through the turbine.

*Example:*

*Exhaust manifold pressure (EMP) = 15 psi*

*Turbine outlet pressure (Outlet P) = 1 psi*

*Atmosphere (Atmos) = 14.7 psi at sea level*

$$ER = \frac{EMP + Atmos}{Outlet P + Atmos} = \frac{15 + 14.7}{1 + 14.7} = 1.89$$

**2. Turbine Corrected Flow** – The turbine flow is also corrected for temperature and pressure at the turbine inlet (exhaust manifold).

*Example:*

*Engine air flow (Actual Flow) = 50 lb/min*

*Exhaust manifold pressure (EMP) = 25 psi*

*Exhaust temperature (Gas Temp) = 1500° F*

*Barometric Pressure (Baro) = 14.7 psi*

$$Corrected\ Flow = \frac{Actual\ Flow \sqrt{[(Gas\ Temp + 460)/519]}}{(Baro + EMP)/14.7}$$

$$Corrected\ Flow = \frac{50 * \sqrt{[(1500 + 460)/519]}}{(14.7 + 25)/14.7} = 36\ lb/min$$

(continued)

### Compressor Maps:

**1. Pressure Ratio** – Ratio of ABSOLUTE outlet pressure divided by ABSOLUTE inlet pressure.

*Example:*

*Intake manifold pressure (Boost) = 12 psi*

*Pressure drop, intercooler ( $\Delta P_{\text{Intercooler}}$ ) = 2 psi*

*Pressure drop, air filter ( $\Delta P_{\text{Air Filter}}$ ) = 0.5 psi*

*Atmosphere (Atmos) = 14.7 psi at sea level*

$$PR = \frac{\text{Boost} + \Delta P_{\text{Intercooler}} + \text{Atmos}}{\text{Atmos} - \Delta P_{\text{Air Filter}}}$$

$$PR = \frac{12 + 2 + 14.7}{14.7 - .5} = 2.02$$

**2. Corrected Airflow** – Represents the corrected mass flow rate of air, taking into account air density (ambient temperature and pressure).

*Example:*

*Air Temperature (Air Temp) = 60° F*

*Barometric Pressure (Baro) = 14.7 psi*

*Engine air consumption (Actual Flow) = 50 lb/min*

$$\text{Corrected Flow} = \frac{\text{Actual Flow} \sqrt{([\text{Air Temp} + 460]/545)}}{\text{Baro}/13.95}$$

$$\text{Corrected Flow} = \frac{50 \sqrt{([60 + 460]/545)}}{14.7/13.95} = 46.3 \text{ lb/min}$$

- 3. Efficiency Contours** – The efficiency contours depict the regional efficiency of the compressor set. This efficiency is simply the percentage of turbo shaft power that converts to actual air compression. When sizing a turbo, it is important to maintain the proposed lugline with a high efficiency range on the map.
- 4. Surge Line** – The surge region, located on the left-hand side of the compressor map, is an area of flow instability typically caused by compressor inducer stall. The turbo should be sized so that the engine does not operate in the surge range. When turbochargers operate in surge for long periods of time, bearing failures may occur.
- 5. Choke Line** – The choke line is on the right hand side of the compressor map and represents the flow limit. When a turbocharger is run deep into choke, turbo speeds will increase dramatically while compressor efficiency will plunge (very high compressor outlet temps), and turbo durability will be compromised.

### WHAT IT TAKES TO BECOME A GARRETT TURBOCHARGER!

Do you know what tests your turbo has endured??? Garrett is one of the few turbocharging manufacturers that subjects our turbo's to several OE qualification tests. These turbocharging "qual tests" ensure Garrett produces a safe and reliable turbo for OE applications. When you buy a Garrett turbo you can be sure it is a reliable one!

- ▶ **On-Engine Durability** – A 1,000-hour general turbocharger durability test that is run on-engine in one of Garrett's engineering laboratories. Some engines die before our turbos do!
- ▶ **Gas Stand Cyclic Durability** (aka The Non-Sissy Test) – A 500 hour general turbocharger durability test. This is basically a "beat the crap out of the turbo" test. Survive this one and you've got one tough turbo!
- ▶ **Compressor & Turbine Housing Containment** - A compressor/turbine wheel is weakened to "hub" burst at a specific speed. No portion of the wheel is allowed to penetrate a "containment shroud" surrounding the turbocharger. A test to ensure safety.
- ▶ **Shaft Motion** - The maximum tolerances of the bearing system are tested for rotordynamic stability beyond the maximum turbocharger operating speed. This means no bearing problems and a long turbo life.
- ▶ **Thrust Bearing Capacity** - A test that stresses the thrust bearing at extreme conditions. This test makes sure your Garrett turbocharger can tolerate the load you put it through.
- ▶ **Compressor & Turbine Seal** - Multiple turbochargers are run on-engine under conditions designed to cause seal leakage. No significant leakage is allowed during these tests.
- ▶ **Heat Soakback** - A turbocharger instrumented with thermocouples is taken beyond maximum operating temperature and shut down hard! Repeat the test four more times and make sure maximum temperatures stay within our strict limits to avoid oil "coking" or build up inside the center housing. This is particularly critical for high temperature gasoline applications.

*(continued)*

- ▶ **Compressor & Turbine Performance** - The entire operating range of both the compressor and turbine are mapped on one of Garrett's "Performance Gas Stands." These test cells are calibrated to strict standards to assure accuracy and consistency.
- ▶ **Compressor & Turbine Blade Frequencies** - Garrett has strict requirements for compressor and turbine blade natural frequency. This is critical on large trims where the blade must be stiff enough to withstand potentially damaging vibrations.
- ▶ **Thermal Cycle** - A 200-hour endurance test that cycles the turbocharger from low temperature to "glowing red" every 10 minutes. To ensure a long turbo life, no cracking of the turbine housing or distortion of the heat shroud are allowed.
- ▶ **Rotor Inertia** - A measurement made to document the rotational inertia of Garrett's compressor and turbine wheels. Garrett's products are known for their high flow / low inertia characteristics.
- ▶ **Shaft Critical Speed** - An analytical "test" that ensures that destructive shaft "critical speeds" are well out of the turbocharger operating range. For example, large wheels may require a large shaft diameter to avoid the "shaft bending" critical speed.
- ▶ **Compressor Fatigue** - Garrett will not sell compressor or turbine wheel castings that have not passed a strict "test to failure" cyclic fatigue test. Garrett runs tests on a regular basis to ensure quality and to constantly improve our products.
- ▶ **Turbo Vibration** - The entire turbocharger is vibrated on Garrett's large shaker table. Vibration levels are monitored to ensure product durability.

### Statement of Warranty

YOU, THE BUYER, MAY CHOSE IN YOUR SOLE DISCRETION TO RESELL OR USE GARRETT ENGINE BOOSTING SYSTEMS PERFORMANCE PRODUCTS FOR RACING VEHICLES, WHICH ARE INHERENTLY DANGEROUS AND MAY NEVER BE DRIVEN ON A PUBLIC ROADWAY. GARRETT, THE SELLER, DISCLAIMS ANY AND ALL LIABILITY ASSOCIATED WITH RACING VEHICLES AND COMPONENTS. ACCORDINGLY, NOTWITHSTANDING ANYTHING TO THE CONTRARY CONTAINED IN BUYER'S PURCHASE ORDER TERMS AND CONDITIONS OR SELLER'S SALES ORDER TERMS AND CONDITIONS OR OTHER PUBLICATIONS (INCLUDING THIS CATALOGUE), OR CONTAINED IN ANY OTHER AGREEMENTS BETWEEN THE PARTIES, SELLER MAKES NO REPRESENTATION OR WARRANTY WHATSOEVER, EXPRESS OR IMPLIED, INCLUDING BUT NOT LIMITED TO ANY IMPLIED WARRANTY OR REPRESENTATION AS TO CONDITION, MERCHANTABILITY, FITNESS FOR A PARTICULAR PURPOSE OR SUITABILITY AS TO ANY OF THE ITEMS LISTED IN THIS CATALOGUE. ALL ITEMS ARE BEING SOLD ON AN "AS IS" BASIS. IN NO EVENT SHALL SELLER OR ANY OF ITS AFFILIATES BE LIABLE IN CONNECTION WITH PRODUCTS LISTED IN THIS CATALOGUE FOR SPECIAL, PUNITIVE, INCIDENTAL OR CONSEQUENTIAL DAMAGES, INCLUDING LOST PROFITS, TO THE FULL EXTENT THESE DAMAGES MAY BE DISCLAIMED BY LAW. YOU MAY HAVE OTHER RIGHTS THAT DIFFER FROM STATE TO STATE.

### Use of compressor maps and turbine maps

Proprietary Notice: This document contains proprietary information, and such information may not be reused or disclosed to others for any purpose, or used for manufacturing without written permission from Honeywell Inc.

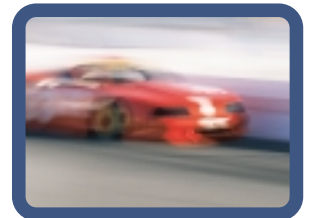

**Garrett®**

*PERFORMANCE PRODUCTS*

**Garrett**

**PROJECT VEHICLES**

**Garrett®**

***PERFORMANCE PRODUCTS***

**Garrett**

***APPENDIX***

## Appendix A

**TURBO TERMS**

**A/R-** A/R describes a geometric property of all compressor and turbine housings. Increasing compressor A/R optimizes the performance for low boost applications. Changing turbine A/R has many effects. By going to a larger turbine A/R, the turbo comes up on boost at a higher engine speed, the flow capacity of the turbine is increased and less flow is wastegated, there is less engine backpressure, and engine volumetric efficiency is increased resulting in more overall power.

**CHRA-** center housing rotating assembly – The CHRA includes a complete turbocharger minus the compressor, turbine housing, and actuator.

**Clipped Turbine Wheels-** When an angle is machined on the turbine wheel exducer (outlet side), the wheel is said to be ‘clipped’. Clipping causes a minor increase in the wheel’s flow capability, however, it dramatically lowers the turbo efficiency. This reduction causes the turbo to come up on boost at a later engine speed (increased turbo lag). High performance applications should never use a clipped turbine wheel. All Garrett GT turbos use modern unclipped turbine wheels.

**Free-Float-** A free floating turbocharger has no wastegate device. This turbocharger can’t control its own boost levels. For performance applications, the user must install an external wastegate.

**GT-** The GT designation refers to Garrett’s state-of-the-art turbocharger line. All GT turbos use modern compressor and turbine aerodynamics which represent huge efficiency improvements over the old T2, T3, T3/T4, T04 products. The net result is increased durability, higher boost, and more engine power over the older product line.

**On-Center Turbine Housings-** On-center turbine housings refer to an outdated style of turbine housing with a centered turbine inlet pad. The inlet pad is centered on the turbo’s axis of rotation instead of being tangentially located. Using an on-center housing will significantly lower the turbine’s efficiency. This results in increased turbo lag, more backpressure, lower engine volumetric efficiency, and less overall engine power. No Garrett OEM’s use on-center housings.

**Trim-** Trim is an area ratio used to describe both turbine and compressor wheels. Trim is calculated using the inducer and exducer diameters. As trim is increased, the wheel can support more air/gas flow. Use these formulas when calculating trim:

$$Trim_{Compressor} = \frac{(Inducer\ Diameter)^2}{(Exducer\ Diameter)^2} \times 100$$

$$Trim_{Turbine} = \frac{(Exducer\ Diameter)^2}{(Inducer\ Diameter)^2} \times 100$$

**Wastegate-** A wastegated turbocharger includes an integral device to limit turbo boost. This consists of a pneumatic actuator connected to a valve assembly mounted inside the turbine housing. By connecting the pneumatic actuator to boost pressure, the turbo is able to limit its maximum boost output. The net result is increased durability, quicker time to boost, and adjustability of boost.